

## UPSTREAM PRESSURE REGULATING VALVE - SERIES 700

### INTRODUCTION

These are self operated upstream pressure regulating control valve, used in many applications for limiting pressure buildup (i.e. prevent overpressure) at its location in pressure system. The valve open in proportion to inlet pressure preventing a rise of internal pressure in excess of a specified value. This valves finds wide applications for upstream pressure control and various kinds of fluids used in chemical process industries Fertilizers and Petrochemical plants, Refineries. Pharmaceutical and food processing plants.

### SPECIFICATIONS

<b>DESIGN</b>	: ASME B16-34
<b>BODY TYPE</b>	: Globe.
<b>VALVE FORM</b>	: 15 to 150 mm ( 1/2" to 6" )
<b>VALVE TYPE</b>	: 1) Direct Operated 2) Pilot Operated
<b>RATING</b>	: ANSI 150 and 300, Higher on request.
<b>END CONNECTION</b>	: Flanged - 15mm to 150mm ( 1/2" to 6" ) Screwed - 15mm to 50mm ( 1/2" to 2" )
<b>AVAILABLE CONFIGURATION</b>	: As per set pressure & flow requirements, different diaphragm size are available.
<b>SENSING DIAPHRAGM</b>	: Neoprene, Nitrile, Viton, EDPM, Silicon, Teflon etc.
<b>BODY MATERIAL</b>	: A216 Gr. WCB, CF8 / CF8M as standard. Other on Request.
<b>INTERNAL PARTS</b>	: S.S. as standard, others on request.
<b>TEMPERATURE</b>	: 25°C to 70°C for Nitrile elastomer parts 15° to 175°C for Viton.
<b>SEAT LEAKAGE</b>	: As per FCI-70-2 (ANSI B 16.104) Class IV, V and VI ( STANDARD LEAKAGE RATES ) Metal to Soft Seating - Bubble tight (Zero Leakage)
<b>PRESSURE SETTING ADJUSTMENT</b>	: May be adjusted through out a spring range by turning the adjusting screw.
<b>PRESSURE REGISTRATION</b>	: Internal (Standard) or Upstream Control Line.

### DESIGN FEATURES

- >> Glandless Construction: - Where positive Zero gland packing is required, the design scores over conventional solutions such as bellow seals etc. as the gland itself is eliminated.
- >> Wide range of body sizes and trim sizes to satisfy varied flow requirements.
- >> Tight sensitively and stability of controlled pressure.
- >> Provides excellent tight shut off capability over long working life.
- >> Compact design with minimum number of moving parts.
- >> Simple resetting.

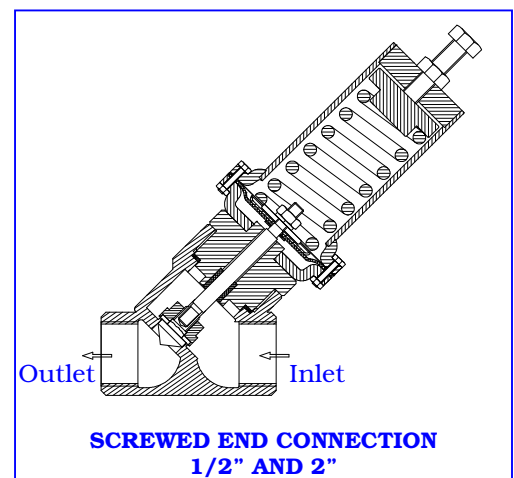
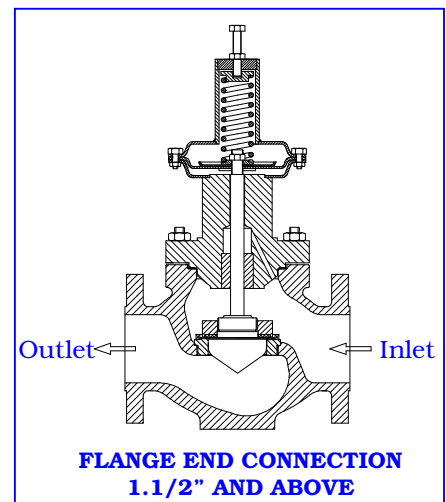
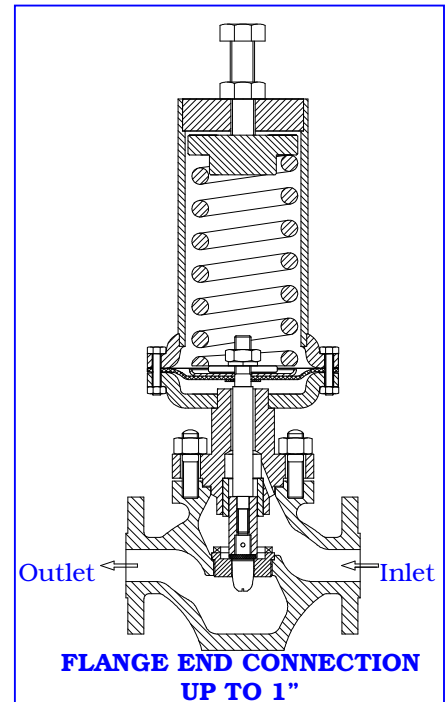

## QUALITY AND PERFORMANCE GUARANTEE

- >> Produced with Quality Systems accredited to ISO 9001 : 2000 ( Certificate No. 208920) by Bureau Veritas.
- >> Full material certification available for all major component Parts.
- >> Full guarantee on design and Performance.
- >> All testing are performed to the requirements of ANSI B16.34.

## PRINCIPLE OF OPERATION

The upstream pressure is registered under the diaphragm opposing the spring when the upstream pressure reaches the set point, the spring is compressed allowing the valve plug to open and relieve excess pressure.

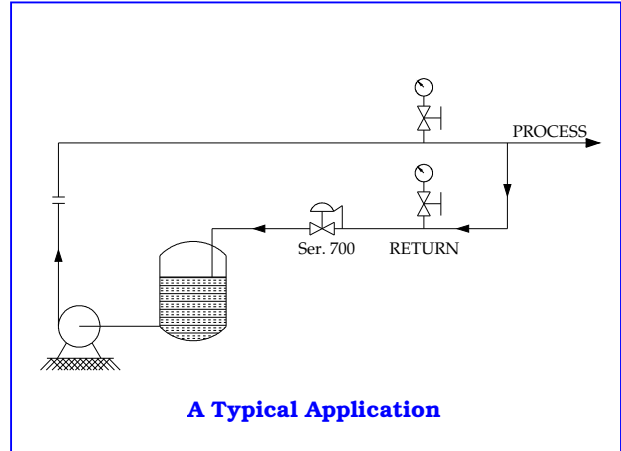
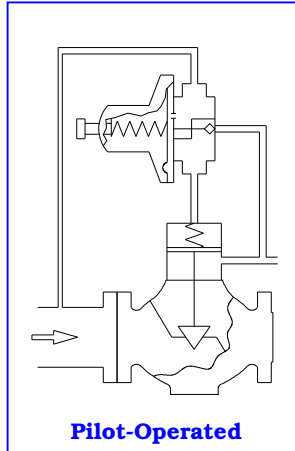
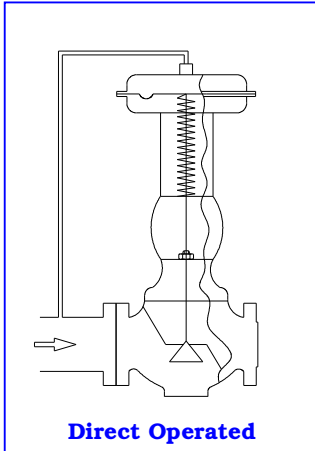

## SELECTION CRITERIA

- >> Familiarize yourself with the application consideration as they apply to your control requirements.
- >> Inlet pressure setting and maximum allowable pressure buildup over the setting.
- >> Normal and maximum inlet pressure.
- >> Minimum, normal, and maximum flow rates.
- >> Name, temperature and specific gravity of controlled fluid.
- >> Inlet and outlet pipe size.
- >> Installation.
- >> Environmental considerations, such as noise level, corrosion, temperature extremes, etc.
- >> Special capabilities such as gauges, test connections, etc.

For final and optimum selection, contact Pneucon sales office / factory who will assist you in selecting the type and size that best suits your need.

The Company's policy is one of continuous product improvement and the right is reserved to modify the specifications contained herein without notice.