



HIGH VOLUME BOOSTER (MODEL - VB-2)

INTRODUCTION

High Volume Booster with a fixed minimum deadband is designed to substantially increase stroking speeds of large actuators. Actuators retain their normal slow and stable responses as long as their signal fluctuations remain within the deadband limits that can be set on the booster.

SPECIFICATION

Connections	: ½" or ¾" NPT (F)
Port Size	: Supply Port ½" or ¾" NPT (F) Exhaust Port ½" or ¾" NPT (F)
Max. Supply Pressure	: Must be same as final control device. Upto 40 psig normally used with diaphragm actuators. Upto 150 Psig normally used with piston actuators.
Pressure Ratio	: 1:1
Deadband Width	: 1psi or 5% of output span, whichever is greater.
Flow capacity	: 115 scfm (195.4m ³ / hr)
Maximum Cv	: 3.0.
Temperature	: - 20° to 70° C
M.O.C.	: Aluminum LM6 or Stainless steel

DESIGN AND PERFORMANCE FEATURES

- >> **Quick Response:-** Provides large volume for rapid stroking of the actuator when confronted with input signals exceeding preset magnitude and rate capabilities. Stroking period can be reduced from one minute to less than three seconds using ¾" High Volume Booster on 300 sq. inch diaphragm actuator having 3 ½" stroke.
- >> **Greater Stability:-** Allows normally slow actuator response to the small or slow signal changes produced by usual process variations.
- >> **Low Air Consumption:-** Soft seats provide tight shutoff to prevent unnecessary air consumption.
- >> **Accuracy:-** Maintains correct actuator position at high stroking speeds.

OPERATION

During steady process conditions when Controller output variations are small, the controller or valve positioner signal to the booster input will be registered through the bypass valve directly to the actuator. Both booster ports remain tightly shut; soft seats preventing unnecessary air consumption.

Because of the bypass valve restriction, larger or faster signal changes will be registered sooner on the booster input than in the booster output chamber connected to the actuator. When the differential pressure exceeds the deadband value of the booster, the diaphragm assembly will move so as to open one, or the other, booster port and allow rapid actuator pressure change. When the controller or positioner senses that the corrective action is completed, the booster closes and lets the actuator return to normal operation.

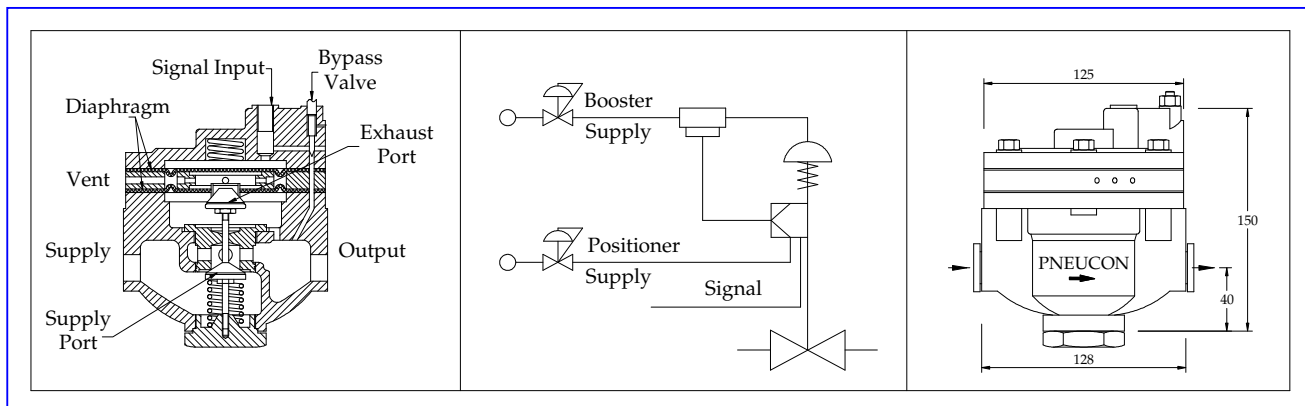

The Company's policy is one of continuous product improvement and the right is reserved to modify the specifications contained herein without notice.

ACAD/PVCT/PVCT-HVB

ISO - 9001 : 2000



Certificate No. 208920



PNEUCON VALVES PVT. LTD.

Plot No. : A-35, Road No. 10, Wagle Industrial Estate, Thane-400 604, India.
 Phone: +91 22 2583 8371, 2583 8372, 2583 8369. Fax : +91 22 2583 8373
 E-mail : info@pneuconvalves.com Website : www.pneuconvalves.com

BUILT IN RELIABILITY

PVCT - HVB