



VOLUME BOOSTER (MODEL - VB-1)

INTRODUCTION

VOLOUME BOOSTER is a high volume amplifier used to increase the operating speed of the actuator, preventing the time lags, in the systems where controller & the control valve are separated by extremely long piping runs.

VOLOUME BOOSTER receives the low volume signal from the controller & transmits from an auxiliary supply a high volume signal to the control valve actuator.

VOLOUME BOOSTER is specially recommended for the use with large capacity diaphragm actuator.

SPECIFICATIONS

Connections : 1/ 4" NPT (F)

Max. Supply Pressure : Must be same as final control device. Upto 40 psig normally used with diaphragm actuators. Upto 150 Psig normally used with piston actuators.

Pressure Ratio : 1:1

Output Capacity : 13.5 SCFM

Flow Capacity (Cv) : 1.02

Reproducibility : 0.1 %

Temperature : - 20° to 70° C

M.O.C. : Aluminum LM6 or Stainless steel

DESIGN AND PERFORMANCE FEATURES

- >> Improves the stroking speed of large diaphragm actuated valves.
- >> Allows normally slow actuator response to the slow signal changes produced by usual process variations.
- >> Soft seat provides tight shut off to prevent unnecessary air consumption.

PRINCIPAL OF OPERATION

Input pressure acting upon the effective area of the upper diaphragm produces a force, which is opposed by the output pressure exerted upon the effective area of the lower diaphragm. The opposing forces are in direct 1:1 ratio. Hence any increase in the input pressure will cause the diaphragm assembly opening the pilot valve to admit a sufficient supply of air to the output to rebalance the input pressure.

A decrease in input pressure will cause the diaphragm assembly to lift off the exhaust port reducing the output and again rebalancing the input. Equalising valve, by-passes slow small signal variations.

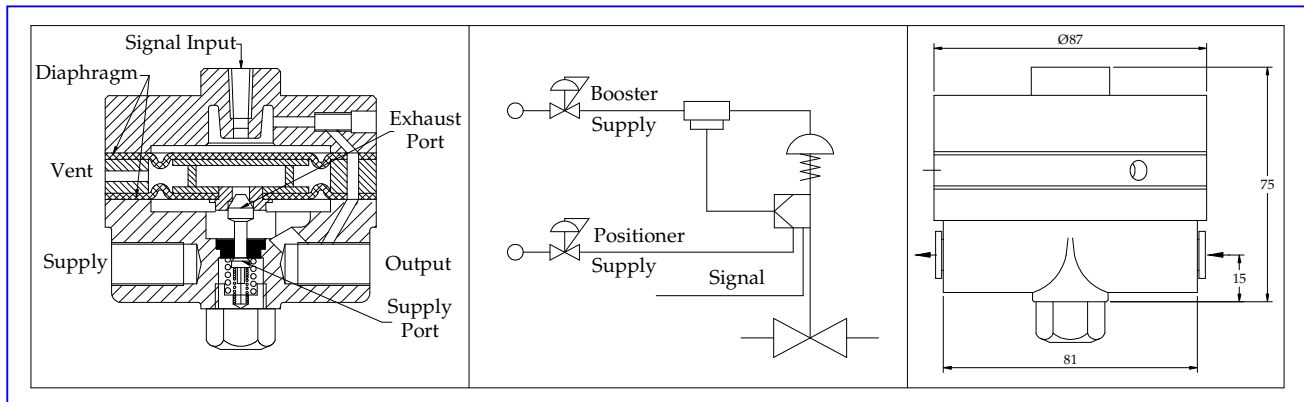

The Company's policy is one of continuous product improvement and the right is reserved to modify the specifications contained herein without notice.

ISO - 9001 : 2000



Certificate No. 208920



PNEUCON VALVES PVT. LTD.

Plot No: A-35, Road No. 10, Wagle Industrial Estate,
Thane - 400 604, India.

Phone: +9122 2583 8371, 2583 8372, Fax : +9122 2583 8373
E-Mail: info@pneuconvalves.com Web: www.pneuconvalves.com

BUILT IN RELIABILITY