

V- NOTCH BALL VALVE

INTRODUCTION

The V-Notch Ball Valve gives non-clogging, high capacity, straight through flow control of fluids containing pulp and paper stock or slurries and fluids containing suspended solids or fibrous materials.

V-Notch Ball Valve is quarter turn valve with a segment Ball. The V-Ball create a wedging and shearing effect prevent the dragging of stock or slurry between the ball and its seal

The V- Notch Ball Valves are offered squared and clamped driven shaft plus ball shaft with splined connection designed for zero lost motion for highly accurate positioning and precise control.

SPECIFICATIONS

DESIGN	: BS. 5351
SERIES	: 310 - 2 Picese Design : 370 - 1 Picese Design
SIZE	: 15 to 300 mm (1/2" to 12")
RATING	: ANSI 150
END CONNECTION	: Flanged End
F/F DIMENSIONS	: ANSI B-16.10
FLOW CHARACTERISTICS.	: Modified Equal Percentage, Linear, On-Off.
FLOW DIRECTION	: Forward (into convex face of V-ball)
MAX. BALL ROTATION	: 90°
BODY MATERIAL	: Carbon Steel, Stainless Steel, And Alloy Steel etc.
BALL MATERIAL	: CF8M Chrome plated/Alloy steels.
SEAT	: Soft /Metal Seat
BALL RING	: CF8M, Alloy steels.
GASKET	: PTFE, Graphite Laminate.
GLAND PACKING	: PTFE V Rings, Grafoil.
ACTUATOR FORM	: Diaphragm, Rotary, Electric.
AIR CONNECTION	: 1/ 4" or 1/ 2" NPT
ACCESSORIES	: Valve Positioner-Pneumatic, Electro Pneumatic, Smart Positioner. Instruments-Airset, Solenoid Valve, Air Lock, Volume Booster, Position Transmitter, Limit Proximity Switches etc. Features- Top or Side Mounted handwheel, Limit Stops

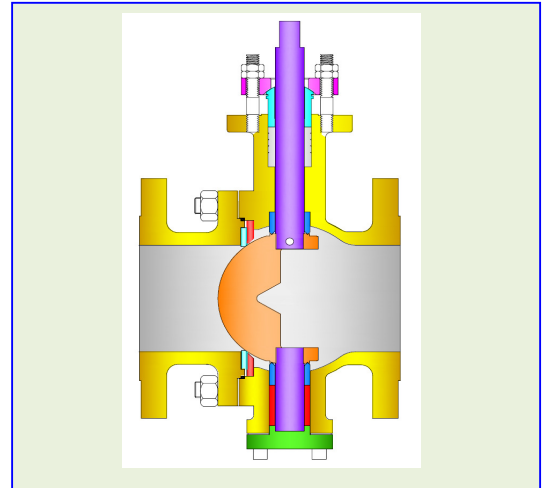

**V-NOTCH BALL VALVE
SERIES - 310**

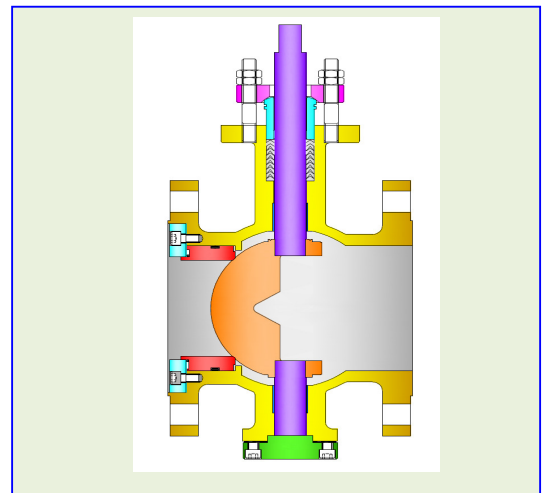

**V-NOTCH BALL VALVE
SERIES - 370**

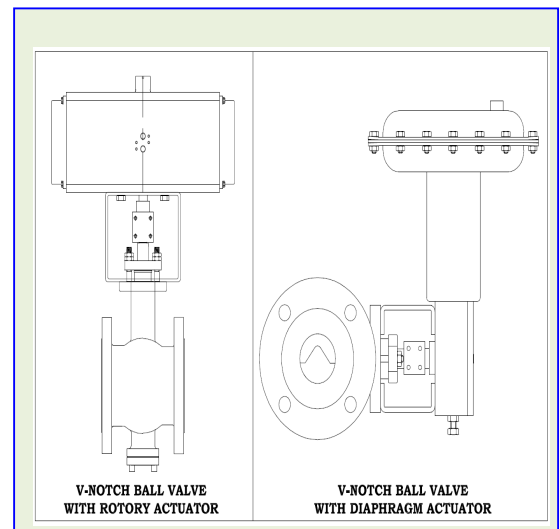

BUILT IN RELIABILITY

DESIGN FEATURES

- >> A Shearing effect between the ball and seal ensures tight shut-off, even on fibrous slurries.
- >> The unrestricted, straight – through flow design provides high capacity and wide rangeability.
- >> Precise contouring of the V-notch balls provides a nearly equal percentage characteristic.
- >> Replaceable ball seal and back up ring for added rigidity.
- >> Ball machined to a super smooth finish, hard – chrome plated and polished to increase Ball seal life.
- >> High Cv to body size ratio.

QUALITY AND PERFORMANCE GUARANTEE

- >> Produced with Quality Systems accredited to ISO 9001: 2008 by Bureau Veritas.
- >> Full material certification available for all major component Parts.
- >> Full guarantee on design and Performance.
- >> All testing are performed to the requirements of ANSI B16.34.

VALVE SIZING CO-EFFICIENT Cv RATING

VALVE SIZE	Inches	1/2	1	1.1/2	2	2.1/2	3	4	6	8	10	12
	mm	15	25	40	50	65	80	100	150	200	250	300
Cv (MAX.) AT 90° OPENING- Series - 310		5	26	78	120	220	325	595	1050	1750	2725	3750
Cv (MAX.) AT 90° OPENING- Series - 370		-	26	65	100	150	260	400	950	1650	2800	3650

**FLOW CHARACTERISTIC CURVES
90° OPENING (Series - 310)**

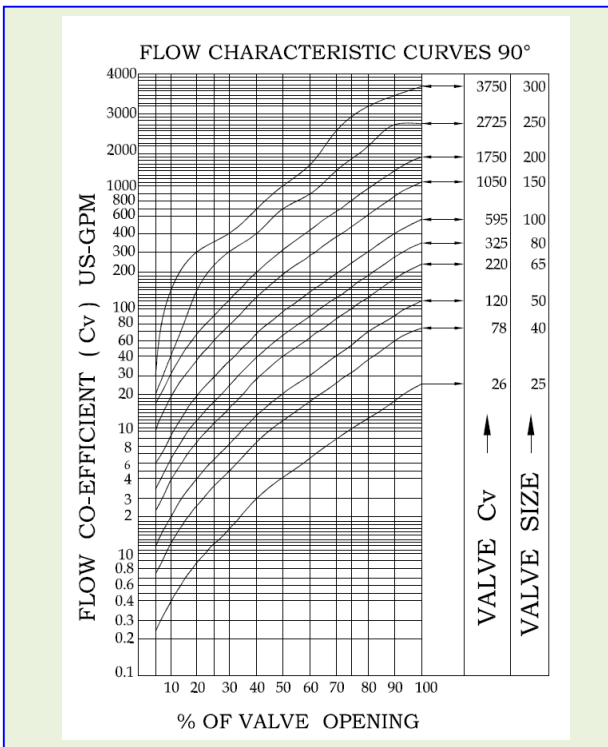

**FLOW CHARACTERISTIC CURVES
90° OPENING (Series - 370)**

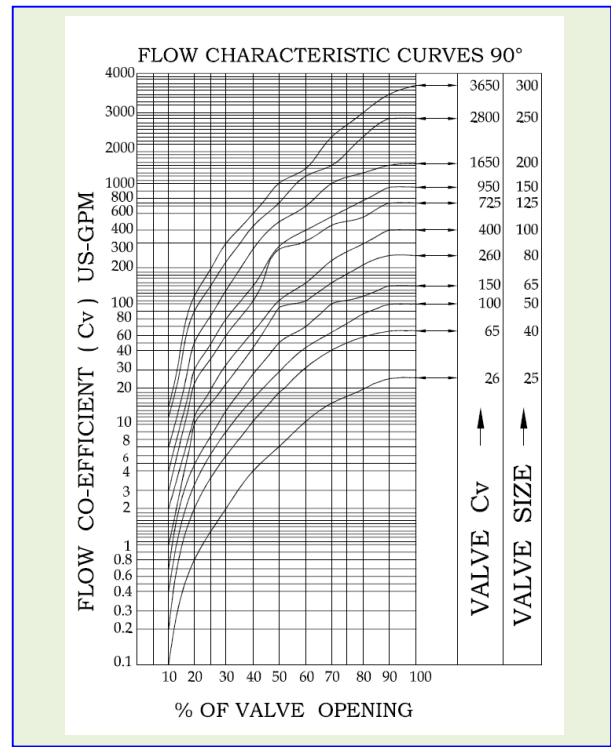

BUILT IN RELIABILITY

MOUNTING DIMENSIONS FOR V-NOTCH BALL VALVE

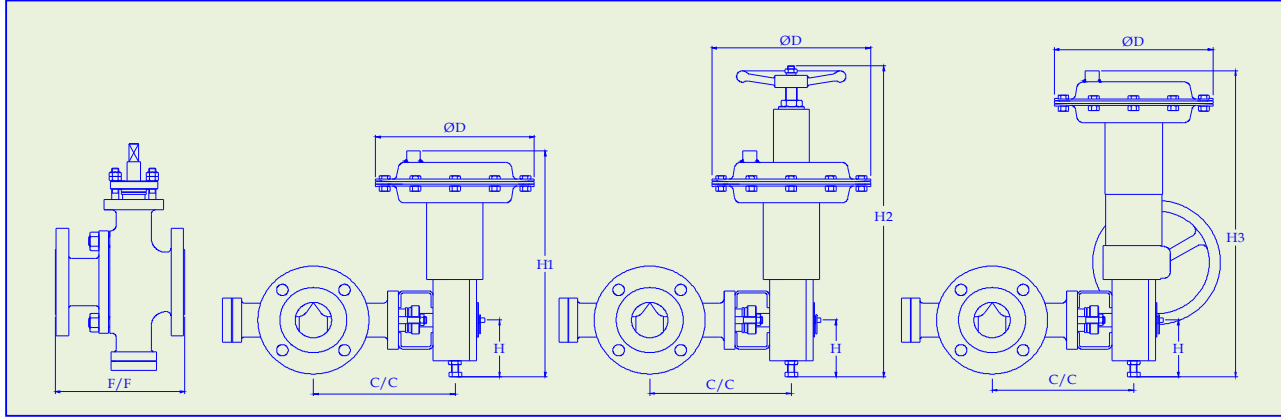

VALVE SIZE	ACTUATOR MODEL	FACE TO FACE ANSI 150		C / C		Ø D	H	STD	TMH	SMH
		310	370	310	370			H1	H2	H3
15	PDS-030-90°	108	-	188	-	218	85	328	488	---
25	PDS-055-90°	127	102	248	248	286	100	432	639	635
40	PDS-055-90°	165	114	280	265	286	100	432	639	635
50	PDS-055-90°	178	124	273	273	286	100	432	639	635
65	PDS-095-90°	190	145	301	325	371	100	466	673	670
80	PDS-095-90°	203	165	301	325	371	100	466	673	670
80	PDS-140-90°	203	165	306	337	443	160	657	944	907
100	PDS-140-90°	229	194	368	368	443	160	657	944	907
150	PDS-140-90°	267	229	396	-	443	170	667	954	917
150	PDS-300-90°	267	229	430	-	616	190	768	N/A	1073
200	PDS-300-90°	292	243	502	-	616	190	768	N/A	1073
250	PDS-300-90°	330	297	530	-	616	190	768	N/A	1073
300	PDS-300-90°	356	338	553	-	616	190	768	N/A	1073

INSTALLATION

The valve should preferably be installed with actuator vertically above or below the valve body. It can be installed in a horizontal or angled position if actuator is suitably supported. Necessary clearance should be provided above the actuator to permit servicing. The flange bolts are to be tightened evenly to avoid placing strain on the body. The inlet of air pressure regulator (Air set) should be connected to the pneumatic supply line. Supply pressure to the diaphragm actuator should be either 1.5 kg/cm² (20 psig) or 2.5 kg/cm² (35 psig) as per indication on the nameplate. For cylinder actuator, supply pressure specified. For control applications, the air set and valve positioner are mounted, piped and adjusted at the factory.

FINAL CHECK

After installation, check the valve operation for full stroke as indicated on the nameplate, check for leaks in air line connection. Open and close the valve two or three times to ensure proper operation. Before commissioning the process flow, it is essential to flush clean the piping properly. Ball valves require minimum maintenance for its operation. Apply a few drops of oil on the exposed guides and bushings, Hand wheel, if present, must be greased periodically.

The Company's policy is one of continuous product improvement and the right is reserved to modify the specifications contained herein without notice.



Plot No: A-35, Road No. 10, Wagle Industrial Estate,
Thane – 400 604, India.

Phone: +91 22 2583 8371, 2583 8372, Fax : +9122 2583 8373
E-Mail: info@pneuconvalves.com Web: www.pneuconvalves.com

BUILT IN RELIABILITY

