

INSTALLATION AND MAINTENANCE AND OPERATING MANUAL BALL VALVE - SERIES 350

CONTENTS

Section	Description	Page No.
1	General	1
2	Warnings / Handling	2
3	Pre-Installation / Installation	3-4
4	Maintenance	4-8
5	Troubleshooting	8-9
6	Schematic Line Diagram of Accessories	10
7	Valve Assembly Drawings with Part List	11
8	Actuator Assembly Drawings with Part List	11-12

>> 1. GENERAL

This manual describes the instructions for handling, storage, installation, maintenance, and operation of the 'Ball Valve and spring opposed pneumatic diaphragm actuator / Rotary actuator.

Instructions not detailed in this document shall be performed in accordance with standard and safe acceptable practices as may be required by local codes, specifications and or regulations.

The instruction contained within this manual must be read before undertaking any work on the equipment supplied and if there are any questions please contact Pneucon Valves Pvt. Ltd.

When ordering any spares please specify the unique valve serial number detailed on the equipment nameplate.

If the valve is supplied with ancillary equipment i.e. Valve Positioner - Pneumatic , Electro Pneumatic, Smart Positioner, Airset, Solenoid Valve, Air Lock, Volume Booster, I/P Converter, Position Transmitter, Limit – Proximity Switches etc. A copy of the respective ancillary equipment manual will be provided within the data / documentation package supplied with the valve.

>> **2. WARNINGS**

1. In order to avoid possible injury to personnel or damage to any equipment any 'WARNING' and 'CAUTION' notes must be strictly adhered to. Modification of this product, substitution of non-approved components and use of maintenance procedures other than those detailed within this document could drastically affect the performance, nullify any warranty and be hazardous to personnel and equipment.
2. Personal injury, equipment damage, leakage due to escaping gas or failure of pressure containing component may result if the valve or ancillaries are over pressurized or installed where service condition exceed the limits detailed in the manufacturer's specification or on the valve nameplate. To avoid such injury or damage a relief valve for over pressure protection should be provide as required by industry and sound engineering practices or applicable safety codes.
3. Due to the possibility of both elevated and low temperatures occurring on exposed surfaces of the valve assembly during operation, adequate safety precautions must be taken. This may involve insulating the valve assembly or the provision of safety clothing and equipment to avoid personal injury.
4. When purchased each valve / ball configuration and construction materials are specifically selected to satisfy the particular application, conditions of flow, temperature, pressure drop and controlled fluid conditions for corrosion and erosion. Included within the Pneucon Valve selection process is the consideration of the amount of power conversion allowed to reduce vibration levels within the valve and also the materials of construction are specifically selected for each application. The valve must not be used on any other application, without a review by Pneucon Valves.
5. The valve is not suitable for fire safe service and is not certified for this application or duty. Unless otherwise detailed in the quotation and order documentation the valve will not have been designed to deal with excessive seismic activity or bending moments resulting from misaligned pipe work.
6. It is not intended that externally applied lever arms will be used on the valve and actuator assembly.

>> **3. HANDLING**

1. The weight of the control valve assembly can cause serious injury if it is not handled correctly, using the necessary protective clothing and safety equipment. Adequate lifting equipment must be used and properly attached. Where lifting eyes are provided with the equipment these should be used to enable safe handling of the valve actuator or assembly. All lifting equipments should be used within its defined limitations., applicable codes and safe industrial practices including (but not limited to) the following :
 - Slings to be free of kinks.
 - Lifting hooks to be positioned directly over the load to avoid any severe swinging when lifted.
 - The operator shall ensure that the load is safe and well secured.
2. When lifting the equipment ensure that any slings or hoists are positioned to avoid any damage to the accessories or tubing mounted on the valve.
3. All eyebolts should have a shoulder, which butts against the tapped hole. Use American Drill Bushing CO ADB2300 series safety hoist rings or equivalent should be used. The following table details the safety hoist thread size and the appropriate safe loading that can be applied.

Safety Hoist Ring	Thread Size UNC	Rated Load lbf
ADB-23004	½" -13 x 0.75	2500
ADB-23002	5/8" -11x1	4000
ADB-23007	¾" -10 x 1	5000
ADB-23101	7/8"- 9 x 1	8000
ADB-23105	1"- 8 x 1.25	10000

BUILT IN RELIABILITY

>> **4. PRE – INSTALLATION**

1. The valve should be inspected on receipt to ensure that it has not been damaged during transit. This inspection should be undertaken in a safe and controlled manner as valve equipment can be heavy and have sharp edges. Any damage found should be immediately reported.
2. If a valve assembly is required to be stored for a significant period prior to installation it must be stored in a fire resistant, clean, dry and ventilated environment to avoid damage to the valve, actuator or accessories.
3. The end caps or other protection devices should not be removed from the equipment until the time of installation, in order to help avoid any damage to the flanges and also prevent the ingress of dirt or foreign particles.
4. Clean pipeline thoroughly to flush out foreign particles out of the pipe before fitting the valve on the pipe line to avoid damage of soft seat and ball of the valve.
5. Do not apply extensive force on automation systems, while handling, which may cause misalignment and malfunctioning of the automation system. Especially over tightening of fasteners.
6. Ensure normal position (Air failure or initial position) of the Valve and Automation System as per technical process specification.
7. Ensure Manual Override of Solenoid Valve in OFF position for automatic functioning of the system.
8. Ensure Declutch able Gear Box lever in disengage position for automatic functioning of the system.
9. The exhaust port of Actuator and Solenoid Valve should be properly vented, check for choking.
10. Ensure registered power supply before energizing the Solenoid Valve Coil.
11. Ensure prescribed air pressure to the Actuator and Solenoid Valve.
12. Use clean, dry, filtered and lubricated air for the Actuator and Solenoid Valve.
13. Orientation of FRL and Valve Positioner needs to be vertical position.
14. Avoid dust accumulation on outside surface of valve and automation system.
Prevention: Ensure use of dust cap on all exhaust ports.
15. The filter be drained regularly to avoid accumulation of the moisture in the automation system. Clean the filter element periodically.
16. The mating interface/ sealing face should be protected from Damage Prevention; Ensure sealing of all such surface.
17. The valves having Bore Size 8” and more, the ball shall be in OPEN position to avoid damage to the ball, which may protrude outside the flange.

>> 5. INSTALLATION

- The valve is supplied with a flow direction arrow either cast on to the body or detailed on the nameplate. It is very important that the valve is installed into the pipe work with the correct flow direction.
- Install the valve using accepted piping practices and preferably with suitable lengths of straight pipe work both upstream and downstream.
- The preferred orientation is for the actuator to be vertically upright. If a valve is required to be installed in any other orientation the valve and actuator must be adequately supported.
- Once the pipe and other fittings are complete, insert the valve with appropriate gaskets on either side of valve.
- Then center the valves with the help of straightening studs/rods, inserted through the pipe flange holes and valve flange hole.
- Adjust/center the valve and gaskets, for perfect non flow interference.
- Insert all the studs/bolts and tighten the nuts across for uniform clamping.
- Following installation of the valve an input signal should be applied to the valve actuator in order to check and confirm correct calibration of the assembly.
- All pneumatic air connections should be checked for leaks. During functional testing of the actuator, the valve would be subject to a pressure test at 3.4 barg.
- The gland nuts are factory adjusted and following commissioning further adjustment could be required to stop any stem leakage. It should be pointed out that excessive tightening of the gland studs could result in packing wear or excessive friction.

1. AIR SUPPLY

- Filtered and lubricated air should be provided at actuator systems at prescribed minimum pressure as registered on the actuator. Connect the filter assembly with ¼" BSP piping of air supply or non-corrosive gas.
- One air connection in the case of S.A. (spring return) actuator for air to open port only Two air connections in the case of double acting Actuator for OPEN and CLOSE ports.
- In case of solenoid operated actuator systems, provide one air connection to the inlet of the Solenoid valve and ensure exhaust ports are OPEN or fitted with caps or silencers.
- In case of Air Regulator provide main air supply connection to the inlet and regulator the desired pressure.

2. POWER SUPPLY

- Ensure registered power supply to the leads or connectors of the solenoid coil.
- In case of power failure, operate the valve with in-built manual override (Push button type, Screw Head Type or Knob Type) hold this manual mode for the process requirement then switch to auto mode for automation.

3. POSITION INDICATOR

- Position Indicators are provided with Micro Switches or Limits Switches separately. The Cam adjustment is factory set and Marked for OPEN and CLOSE indications in remote working conditions. A transparent dome is provided on the dual colour indication for OPEN and CLOSE position. Connected leads of Micro Switches should be in circuit as required by process instrumentation. Wiring diagram is attached to ensure right connection.

>> 6. MAINTENANCE

Maintenance such as diaphragm or gland packing can be done without removing the valve from the line.

1. REMOVAL OF ACTUATOR FROM VALVE

- Remove instrument tubing, air set, Positioner, and any other accessory that maybe mounted on the control valve unit
- Unscrew the coupling. (Part No:-22)
- Unscrew the actuator from bracket. (Part No:-20)
- Pull off the actuator from the bracket.

2. DIAPHRAGM REPLACEMENT

- Using the spring adjuster the spring compression should be relieved.
- Remove travel indicator and indicator screw. (Part No:-16 & 42)
- Unscrew allenkey bolt of rotary box cover. (Part No:-33)
- Pull off pinion assembly (Pinion + Pinion shaft)
- Unscrew the assembly bolts of rack guide.
- Remove rack from the actuator shaft by rotating the rack anti clock wise.
- Remove the diaphragm case nuts and bolts equally in an alternating pattern. Ensure that all “short” bolting is removed first to separate the casings.
- Remove the diaphragm, diaphragm collar, stem and stem lock nut assembly form the actuator.
- Unscrew the stem lock nut and remove the diaphragm.
- Clean all the internal parts and examine for any damage. Any significantly damaged parts should be replaced.
- Fit the new diaphragm on to the diaphragm collar, stem and stem lock nut assembly and secure the stem lock nut.
- Fit the diaphragm, diaphragm collar, stem and stem lock nut assembly into the actuator.
- Bolt together the diaphragm casings ensuring the bolting is tightened evenly to ensure correct sealing and also prevent damage to casings.
- Using the spring adjuster the spring compression should be applied until the actuator start to operate at the bench set figure detailed on the nameplate.

3. REPLACING FLEXIBLE DIAPHRAGM

- To dismantle actuator form body set, follow as described in Para `TO SEPARATE DIAPHRAGM OPERATED ROTARY ACTUATOR AND ROTARY BOX FROM BODY SET' of this manual.
- Unscrew disc spring & thrust washer.
- Remove flexible diaphragm from the stuffing box.
- Clean the valve shaft and Stuffing box from inside.
- Install new flexible diaphragm.
- Install Actuator on Body set as described in Para ` MOUNTING OF DIAPHRAGM OPERATED ROTARY ACTUATOR ON BODY SET of this manual.

4. REPLACING SEAL RING

- Make sure the valve is in shut position (If the valve action is air to close-apply air pressure to actuator diaphragm to bring the valve in shut position.)
- Remove adaptors by loosening studs/nuts.
- Remove Seal Ring.
- Clean body surfaces and ball ring surfaces for dust and foreign particles.
- Install seal ring.
- Re-tight the body studs/nuts.
- Operate the valve few times.

Note: For replacing seat ring, do not dismantle the Actuator.

5. ACTUATOR FITTING TO VALVE

- For Valve Action Air to Open Keep the Ball Valve in Full closed Position. For valve action air to close keep the Ball Valve in full open position.
- Fix the mounting bracket on Valve Body.
- Mount the complete assembly of Diaphragm Operated Rotary Actuator with Rotary Box, to mounting brackets, the back of Rotary box is provided with four tapped holes, whereas mounting bracket has four holes. Align the holes of mounting bracket with tapped holes of Rotary Box and bolt them up. Care should be taken that the two ends of Pinion Shaft and Ball Shaft are in perfect alignment.
- Mount rack on the actuator stem and position it using rack guide.
- Screw the allenkey bolts of rack guide.
- Applying pneumatic signal pressure to the Diaphragm through air connection provided, stroke the valve a few times and set the stroke by using stroke travel stopper provided at the bottom of Rotary Box. If it is a case of regulating duty valve, set the spring compression by using retainer and spring adjuster, through the opening provided on the spring housing.
- Now close the rotary box using cover plate.
- Operate the valve to full stroke and check the Ball position.
- If there are any accessories e.g. Limit switches, Solenoid Valve, Air Set, etc. fix them up in their respective places.

6. ACCESSORIES FITTING

- Control valve assemblies generally comprise of a valve, actuator and instrumentation. The instrumentation normally includes a Positioner e.g. Pneumatic, E/P or Smart, Volume booster, Airset, Solenoid valve, Air Lock, Quick Exhaust valve and Limit Switches etc.

- The E/P & Smart Positioner needs clean, dry and oil-free instrument air to guarantee fault-free operation. Required quality of instrument air according to ISO/DIS 8572-1:
- Solid content and size: class 2
- Pressure dew point: class 2 (not less than 20 K below lowest ambient temperature)
- Contents of oil: class 2
- When working on the compressed air network, ensure that any contamination such as water, oil, swarf, solder residues etc. Is removed by blowing out.
- Each instrument fitted would have a separate operating and instruction manual and this would be included in the data book. This would detail any specific requirements for the instrument.
- Ensure that a suitable air filter is provided for the equipment in accordance with each instrument.

The pneumatic supply pressure should not exceed the limits detailed for each of the respective instruments

7. SOLENOID OPERATION

- NAMUR Solenoid Valves fitted directly on the actuator connected with both pneumatic & power supply needs to be switched ON for operation.
- Panel mounted solenoid valves require tubing to and from solenoid valves to be done to complete the pneumatic connection & cabling for the solenoid coil power supply.
- Gang type Solenoid Valves requires tubing of 3/8" for air outlet from each solenoid valve to actuator and complete the cabling for solenoid coil power supply. Gangs are panel mounted or platform mounted.
- Based on the process feedback check the solenoid for ON/OFF operation.

NOTE:- Ensure supply of instrument or compressed air free from oil, water and dust to solenoid valves.

Check blockages in the solenoid valve port (INLET and EXHAUST) if tubing/pipeline not purged.

8. MANUAL OVERRIDE (DE-CLUTCHABLE GEAR BOX)

- In case the Valves are to be operated during Power / Air failure do observe the following: The engage/ disengage lever or the manual override needs to be in engaged position as marked on the override.
- The hand wheel provided should be rotated in the direction as marked on the hand wheel for OPENING or CLOSING as desired.
- On completion of emergency operation the Valve should be in the normal position i.e. either normally OPEN or normally CLOSED and left in the disengaged position.

NOTE :- On resuming Power / Air supply , see that all the manual override are in disengaged position for complete Valve automation.

BUILT IN RELIABILITY

9. CAM/POSITION SETTING FOR THE POSITION INDICATOR

- Open the top cover of the Dome enclosure by first removing the Acrylic cover and colored dome. The Acrylic Cover can be pushed up with the help of any insert or screw driver>
- 2 Nos. of Spring loaded Cams are set as per marked to depress and release the roller plunger of the Micro Switch each corresponding to OPEN or COLSE indication>
- The spring-loaded cams can be easily handled by Human Fingers without any tools or gadgets.
- Check if Valve is Normally OPEN or Normally CLOSED.
- The Top Micro Switch is for Normally OPEN indication and lower for Normally CLOSED Indication.
- Adjust the cam accordingly at the maximum diameter to depress the roller plunger of the micro-switch.
- When Valve is OPEN adjust the top Cam so that the indicator light or bulb is switched ON and position the local indicator to match CLOSE with Acrylic visibility.
- When is CLOSED adjust the lower Cam so that the indicator light or bulb is switched ON and Position the Local Indicator to match CLOSED with Acrylic visibility.
- On completion of above close the enclosure fitting the corresponding OPEN/ CLOSED dome the push fit the Acrylic cover to show OPEN/ CLOSED visual corresponding to the Valve position.
- This completes the setting and re-fitment.

**Note: - If Normally OPEN, Anti-clockwise movement of Ball and Actuator to CLOSE.
If Normally CLOSE, Anti-clockwise movement of Ball and Actuator to OPEN.**

10. CAUTION

When order the valve configuration and construction material were selected to meet particular pressure, temperature, pressure drop and controlled fluid condition. Do not apply other conditions to the valve without getting written consent regarding to suitability from Pneucons authorized representation.

>> 7. TROUBLESHOOTING

Control valve normally require seldom attendance, except for routine check on the control valve response in respect of the input signals received from the controller. The following details some of the problems associated with the control valve operation:

SR NO	SYMPTOMS	PROBABLE CAUSES	CORRECTIVE ACTION
I	Excessive leakage when valve closed	Ball in a wrong position relative to the actuator.	Select the correct keyway in the actuator.
		Wrong stop screw adjustment of the actuator.	Adjust the stop screw for closed position.
		Worn out seal.	Replace seal.

II	Actuator not operating	Check the air supply line for any leakage or blocks.	Stop the leakage or clear the blockage in pipe line or tubing.
		Check Actual Air supply pressure available at the actuator is lower than specified pressure.	Increase the supply air pressure to specified pressure.
		Check springs in case of Single Acting Actuator if broken or missing.	Replace the springs after dismantling & re-assembly.
		Check Manual Over ride if in engage (ON) position.	Dis-engage the Manual Over ride.
		Check Solenoid Valve for specified voltage & power supply.	Provide specified voltage & onfrim power supply.
		Check Exhaust port of Solenoid Valve is clear of all blocks.	Clear the blockages of Exhaust.
		Check if inlet of Solenoid Valve is clear of all blocks.	Clear the Air Inlet of Solenoid Valve of all blocks.
		Check valve for jamming.	Clear the jamming of valve by clearing the valve internals.
		Check for air supply to Actuator & power supply to Solenoid Valve.	Confirm specified clean & dry air supply to actuator & power supply to Solenoid Valve.
		Check signal & pressure for control of Valve Positioner & I/P Converter.	Confirm the proper signal & pressure to Valve Positioner & I/P Converter.
III	Rotating of Actuator not matching with the Valve.	Mis-alignment in mounting bracking.	RE-align and correctly level & fix the bracket.
IV	Excessive Blacklash	Free movement between pinion & stem males & female slot due to wear or under size.	Fix the play between pinion & stem or change whichever component possible.
V	Single Acting Actuator not OPENING/CLOSING fully.	Adjustable head cap screw has been disturbed.	Adjust the screw until the retainer just touching the piston.
		Improper spring retainer sealing.	Dismantle & re-assemble correctly.
		Misplaced / Broken springs.	Replace the springs.
VI	Not opening in specified supply air pressure	Manual over ride is engaged.	Dis-engage the manual override of Solenoid Valve & Decluchable Gear Box.
		Solenoid Valve is not operating due to coil voltage & power supply not per specified. Exhaust/Inlet ports blocks.	Confirm the specified voltage & power supply & clear all blocks.
		Breather hole to spring chamber is blocked in Single Acting models.	Clear the blocks of actuator or Solenoid.
		Check air supply for true cross sectional flow on bending & application of sealing tapes.	Air supply tubing needs to be properly done and bended for uniform cross section. Avoid sharp bends.
		Air supply source if at a length from the Actuator.	Avoid this distance to confirm air supply pressure drop for specified pressure to actuator.
VII	Not operating for fail safe position.	Exhaust port of Solenoid Valve is blocked.	Check the port & rectify.

SCHEMATIC LINE DIAGRAM OF BALL VALVE ACCESSORIES

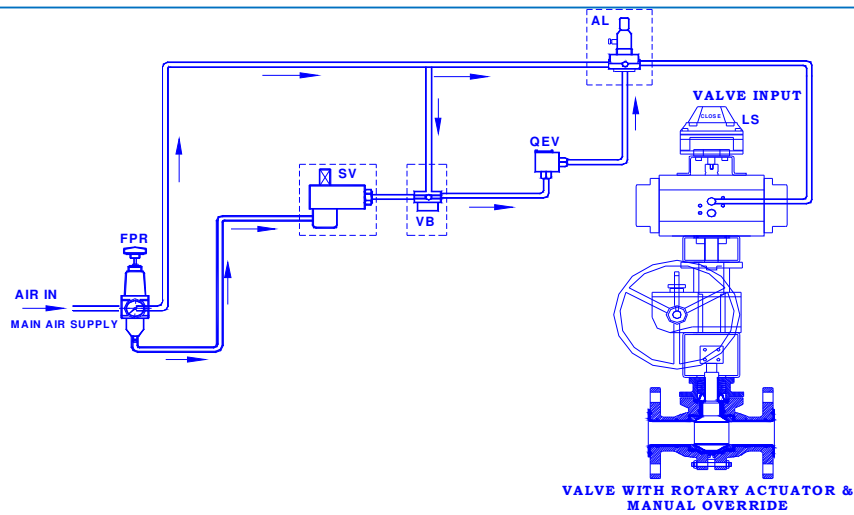
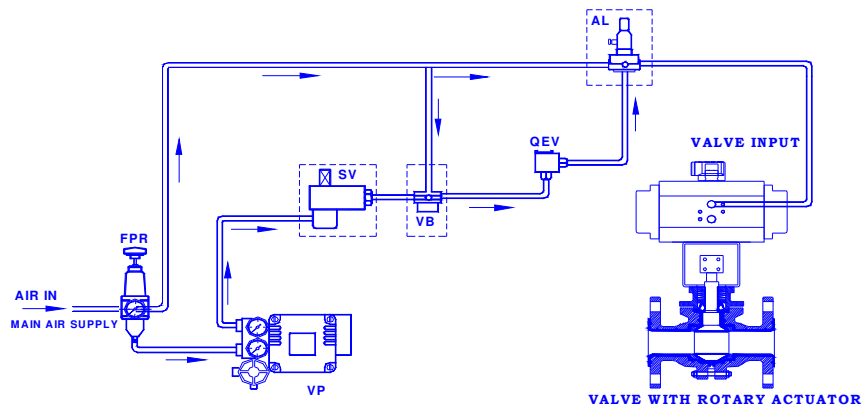
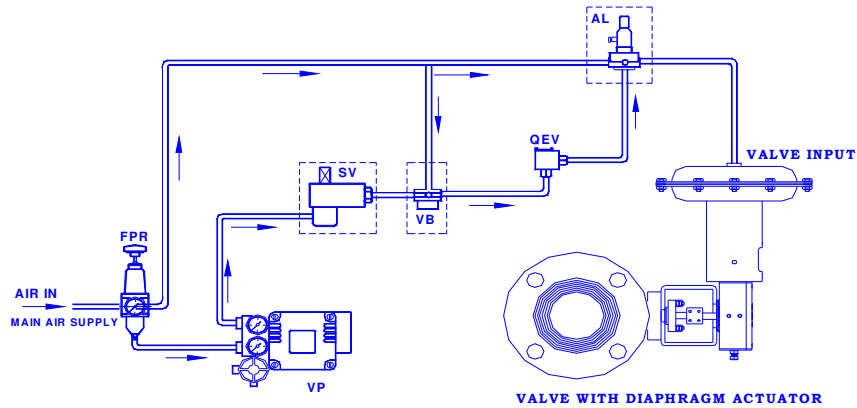

Where,

VP - Valve Positioner-Pneumatic, E/P & Smart
 FPR - Filter Pressure Regulator
 SV - Solenoid Valve
 LS - Limit Switch

VB - Volume Booster
 QE - Quick Exhaust Valve
 AL - Air Lock

General arrangement of accessories is shown in the schematic diagram. The accessories shown in the dotted line can be bypassed.

BUILT IN RELIABILITY

BALL VALVE (SERIES-350) ASSEMBLY

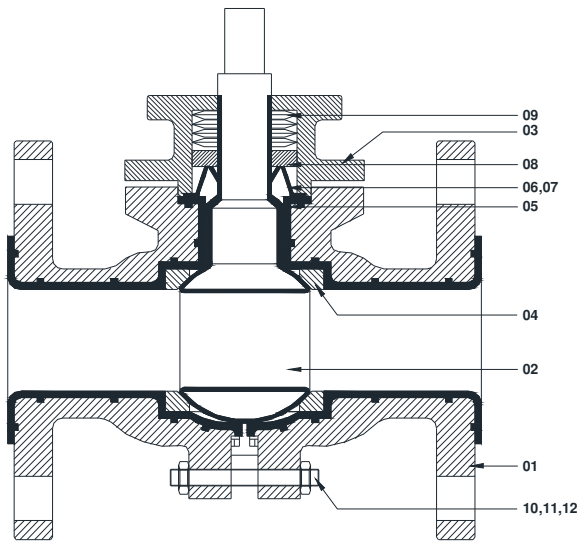

NAME OF PART	PART No.
LINED SIDE PIECE	01
LINED INTEGRAL BALL	02
TOP COVER	03
SEAT RING	* 04
SPHEAR BUSH	05
FLEXIBLE DIAPHRAGM	* 06
DIAPHRAGM BACK UP	07
THRUST WASHER	08
DISC SPRING	09
HEX HEAD BOLT	10
HEX NUT	11
SPRING WASHER	12

* -RECOMMENDED SPARES

SCOTCH ACTUATOR (MODEL PDS)

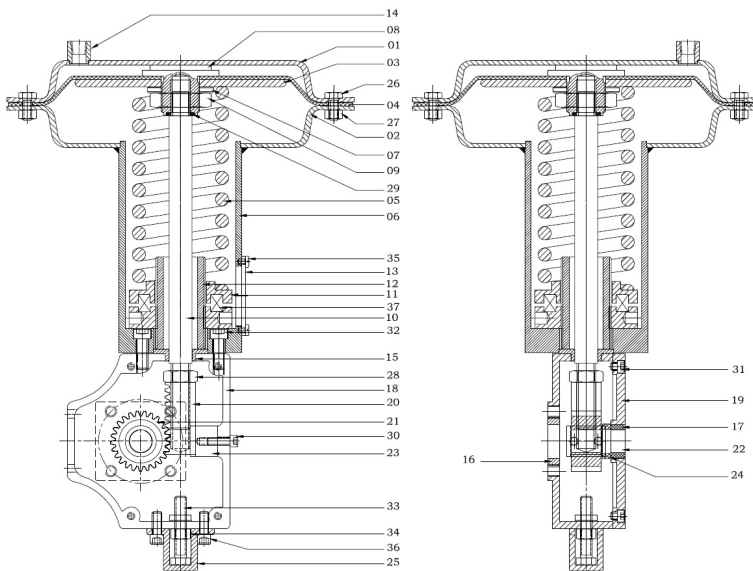

Sr. No.	PART NAME
01	TOP CASING
02	BOTTOM CASING
03	AREA PLATE
* 04	DIAPHRAGM
05	SPRING
06	SPRING TUBE
07	SPRING GUIDE
08	DIAPHRAGM COLLAR
09	DIAPHRAGM COLLER NUT
10	STEM
11	SPRING ADJUSTER
12	SPRING ADJUSTER SCREW
13	WINDOW COVER
14	AIR CONNECTION
15	BUSH FOR STEM
16	BUSH FOR PINION SHAFT GUIDE
17	BUSH FOR ROTARY COVER SIDE
18	ROTARY BOX
19	ROTARY BOX COVER
20	RACK
21	PINION
22	PINION SHAFT
23	RACK GUIDE
24	PINION GUIDE BUSH
25	SPINDLE COVER
26	HEX SCREW FOR CASING
27	HEX NUT FOR CASING
28	HEX LOCK NUT FOR RACK
29	SPRING WASHER S.Q. SECTION
30	ALLEN SCREW FOR RACK GUIDE
31	ALLEN SCREW FOR ROTARY COVER
32	ALLEN SCREW FOR MOUNTING ROTARY BOX
33	HEX SCREW
34	HEX NUT
35	CHS FOR WINDOW COVER
36	ALLEN SCREW FOR SPINDLE COVER
37	THRUST BALL BEARING

* - RECOMMENDED SPARES

SINGLE ACTING ROTARY ACTUATOR

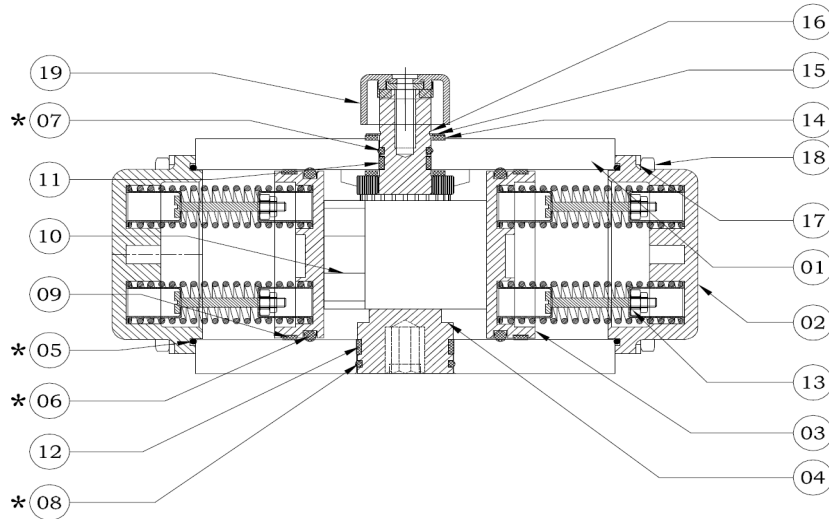

19	INDICATOR
18	ALLEN BOLT
17	SPRING WASHER
16	EXTERNAL CIRCLIP
15	PINION WASHER
14	WASHER FOR PINION
13	SPRING CARTRIDGE
12	PINION BOTTOM GUIDE
11	PINION TOP GUIDE
10	PISTON PAD
9	PISTON GUIDE
8	PINION BOTTOM 'O' RING *
7	PINION TOP 'O' RING *
6	PISTON 'O' RING *
5	END CAP 'O' RING *
4	PINION
3	RACK PISTON
2	END CAP
1	BODY
No	PARTS NAME

DOUBLE ACTING ROTARY ACTUATOR

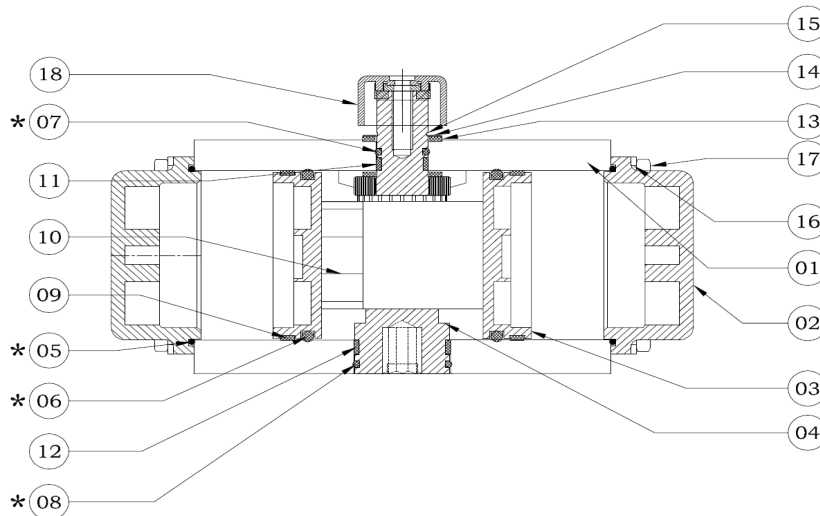

18	INDICATOR
17	ALLEN BOLT
16	SPRING WASHER
15	EXTERNAL CIRCLIP
14	PINION WASHER
13	WASHER FOR PINION
12	PINION BOTTOM GUIDE
11	PINION TOP GUIDE
10	PISTON PAD
9	PISTON GUIDE
8	PINION BOTTOM 'O' RING *
7	PINION TOP 'O' RING *
6	PISTON 'O' RING *
5	END CAP 'O' RING *
4	PINION
3	RACK PISTON
2	END CAP
1	BODY
No	PARTS NAME

* - RECOMMENDED SPARES

In order to avoid possible injury to personnel or damage to valve parts, WARNING and CAUTION notes must be strictly adhered to. Modifying this product, substitution non- factory or inferior parts, or using maintenance procedure other than outlined could drastically affect performance, void product warranties and be hazardous to personnel and equipment.

While ordering spares, please indicate 'Valve Serial No.' appearing on 'Name Plate' fixed on the Actuator. The Company's policy is one of continuous product improvement and the right is reserved to modify the specifications contained herein without notice.



Plot No: A-35, Road No. 10, Wagle Industrial Estate,
Thane - 400 604, India.

Phone: +9122 2583 8371, 2583 8372, Fax: +9122 2583 8373
E-Mail: info@pneuconvalves.com Web: www.pneuconvalves.com

