

BALL VALVE WITH PNEUMATIC ACTUATOR

INTRODUCTION

PNEUCON Ball Valve with pneumatic Piston actuator rack and pinion type are specially designed for on-off application. It is widely used in control of air, water, oil, gas and steam in Pharma, Textile, Chemical, power generation, paper pulp, petrochemical industries etc.

SPECIFICATIONS

BODY DESIGN	: BS 5146, MSS SP 72 & ANSI B 16.34
BODY TYPE	: 2 – piece design
VALVE SIZE	: 15 to 150 mm (1/2” to 6”)
RATING	: ANSI 150, BS 10 Table “F” ETC\
END CONNECTION	: Flanged – 15 to 150 mm (1/2” to 6”) Screwed – 15mm to 150 mm (1/2” to 6”) Socket Weld – 15 mm to 150 mm (1/2” to 6”) Tri Clover End – 15 mm to 50 mm (1/2” to 2”)
BODY MATERIALS	: SS 304, SS 316, CS, CI ETC
BALL	: SS 304 / SS 316
BALL SEAL RING	: Grafoil / PTFE V Rings.
TRIM DESIGNS	: Anti Blow Out.
TRIM MATERIALS	: Stainless Steel 304 / 316.
CHARACTERISTICS	: On / Off.
SEAT LEAKAGE	: Class VI Metal to Soft Seating – Bubble tight (Zero Leakage).
MOUNTING PAD	: As per ISO 5211
ACTUATOR TYPE	: Double Piston (Rack & Pinion).
ACTUATOR ACTION	: Single Acting / Double Acting. Single acting air failure Spring Return Type. Double Acting air failure “Stay Put”
CYLINDER BODY	: Extruded Hardened Aluminum
PINION SHAFT	: EN8 / SS 304 / 316
PISTON RACK	: Hardened Aluminum LM 24
PISTON GUIDES	: 40% BRONZE FILLED TEFLON
SPRINGS	: Pre Loaded Spring SNS (LH/RH) Type
SEALING	: Nitrile (Viton or EPDM available on request)
AIR SUPPLY	: 3.5 – 6 Kg/cm ²
AIR CONNECTION	: 1/ 4” NPT.
OPTIONAL	: 3/2 Way, 5/2 Way Solenoid Valves (220VAC/24VDC)
ACCESSORIES	: Micro & Proximity Limit Switches Air Filter Pressure Regulators Side Mounted Handwheel (Worm Gear Quarter Turn)

(All Accessories available in Fire Safe & Intrinsic Safe Design on request)

DESIGN FEATURES

- Simple construction provides ease in maintenance Without disturbing insulations and piping connections.
- “O” Ring used in Piston provides good pressure seals with minimum friction.
- Compact design hence reduced weight and low cost.
- SNS (LH/RH) spring in spring type.
The introduction of Pre Loaded spring cartridges, That removes the danger in the case of disassemble of spring return actuator and that allows easy change of spring number present inside.
- Long life over 100 thousand cycles

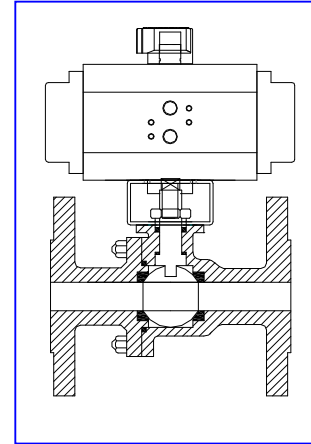

**BALL VALVE WITH
ROTARY ACTUATOR**

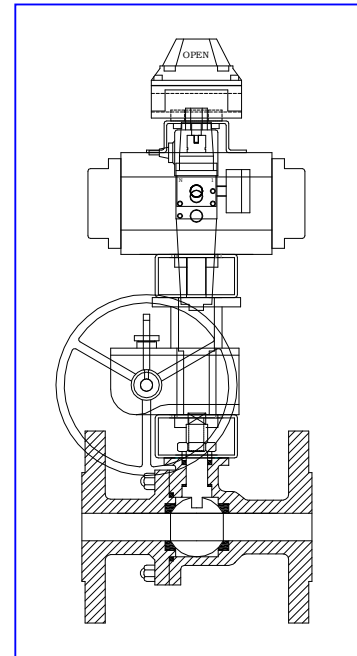

**BALL VALVE WITH
ROTARY ACTUATOR AND
ACCESSORIES**

BUILT IN RELIABILITY

SPECIFICATION TABLE

VALVE SIZE		ACTUATOR MODEL		SAFE WORKING PRESSURE (Kg/Cm2)	ACTUATOR AIR PRESSURE REQUIRED (Kg/Cm2)
INCH	MM	Single Acting	Double Acting		
1/2"	15	056	056	19	3.5 - 5
3/4"	20	056	056	19	3.5 - 5
1"	25	056	056	19	3.5 - 5
1.1/2"	40	069	056	19	3.5 - 5
2"	50	075	069	19	3.5 - 5
2.1/2"	65	075	075	19	3.5 - 5
3"	80	100	075	19	3.5 - 5
4"	100	125	100	19	3.5 - 5
5"	125	N/A	125	19	3.5 - 5
6"	150	N/A	125	19	3.5 - 5

MOUNTING DIMENSIONS FOR 150

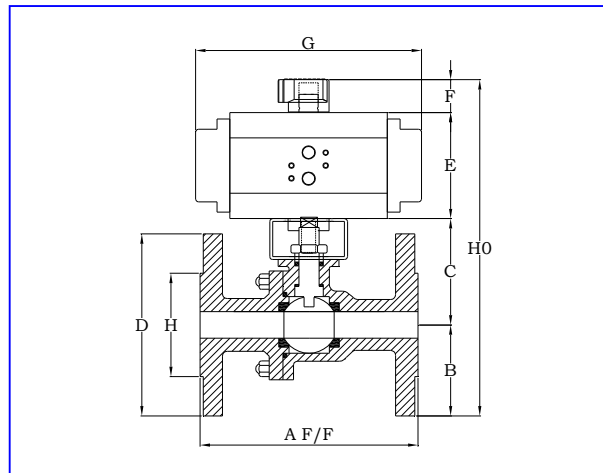

VALVE SIZE		ACTUATOR MODEL	DIMENSIONS (MM)								
Inch	mm		A	B	C	D	E	F	G	H	HO
1/2"	15	RS 056	108	45	67	89	81	25	157	35	217
3/4"	20	RS 056	118	49	67	98	81	25	157	43	221
1"	25	RS 056	127	54	108	108	81	25	157	51	231
1.1/2"	40	RS 069	165	64	127	127	97	25	186	51	279
2"	50	RS 075	178	89	178	178	99	31	211	92	321
2.1/2"	65	RS 075	190	89	178	178	99	31	211	105	344
3"	80	RS 100	203	96	191	191	128	31	266	127	404
4"	100	RS 125	229	115	229	229	128	31	266	157	433
5"	125	RD 125	255	127	180	254	153	21	354	186	481
6"	150	RD 125	267	140	279	279	153	21	354	216	493

Any different technical or dimensional requirement – available on request.

The company's policy is one of continuous product improvement and the right is reserved to modify the specifications contained herein without notice.



BUREAU VERITAS
Certification



UKAS
QUALITY MANAGEMENT



PNEUCON VALVES PVT LTD

Plot No: A-35, Road No. 10, Wagle Industrial Estate,
Thane – 400 604, India.
Phone: +9122 49620350 / 60, Fax : +9122 2583 8373
E-Mail: sales@pneuconvalves.com
Web: www.pneuconvalves.com