

POWER CYLINDER SERIES - 900

INTRODUCTION

The PNEUCON Power Cylinders are widely used for accurately and positively positioning all types of plant regulators such as Dampers, ID and FD. fans in Boilers, Throttle Valves and Butterfly Valves.

Power Cylinder can be arranged so that increase in control pressure moves the position either outwards or inwards.

SPECIFICATIONS

- DESIGN** : Piston Double Acting Cylinder
- CYLINDER BORE** : 2" to 14"
- STROKE** : Upto 20" Standard. Higher sizes on request
- MATERIAL**
- Barrel** : Seamless Honed and Hard Chrome Plated
 - Piston Rod** : EN8 Ground & Hard Chrome Plated.
 - End Caps** : C. I.
 - Seals** : Nitrile.
- WORKING PRESSURE** : 150 psig (11 Kg/cm²g) Maximum
- TEMPERATURE RANGE** : -20°C to +80°C
- SENSITIVITY** : 0.5 % of full stroke
- CONTROL SIGNAL PRESSURE RANGE** : 3-15 psig (0.2-1.0 Kg/cm²g)
- AIR CONSUMPTION** : 1 SCFM of free air at 80 psig (5.6 kg/cm²g)
- THRUST** : Available thrust may be considered as 70% of Cylinder Bore Area multiplied by operating air pressure.
- PISTON POSITION RELATIONSHIP** : Linear
- CONNECTION** : 1/4" NPT(F)/ 1/4" BSP (F)
- ACCESSORIES OPTIONAL** : Valve Positioner - Pneumatic, Electro Pneumatic, Airset, Air Lock, Solenoid Valve, Volume Booster, I/P Converter, Position, Transmitter, Limit Switches, Proximity Switches etc.

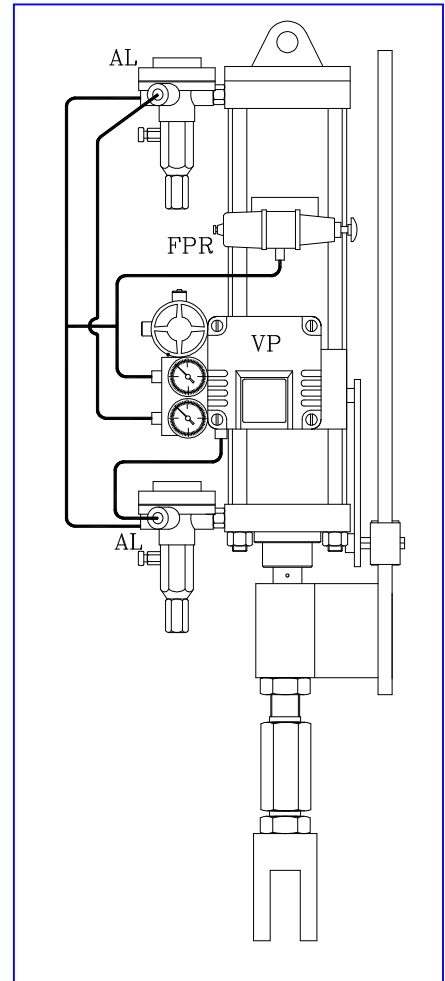

POWER CYLINDER WITH ACCESSORIES

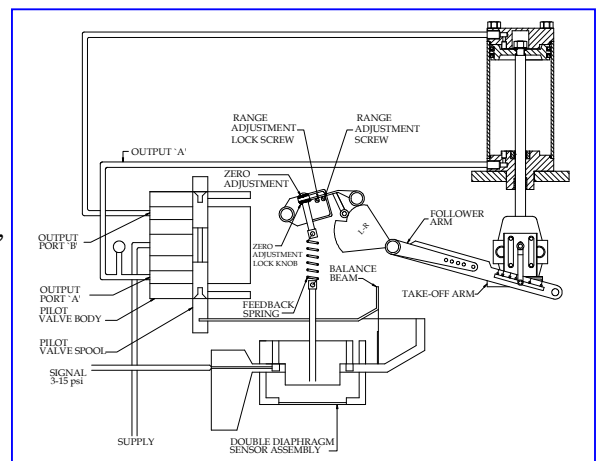

SCHEMATIC DIAGRAM OF D/A VALVE POSITIONER

DESIGN FEATURES

- >> Wide range available to meet most requirements.
- >> Reversal of piston direction in relation to the Control Signal easily achieved on site.
- >> Finish Cylinder barrel and piston rod.
- >> Low friction and long life.

QUALITY AND PERFORMANCE GUARANTEE

- >> Produced with Quality Systems accredited to ISO 9001 : 2000 (Certificate No. 208920.) by Bureau Veritas.
- >> Full material certification available for all major component Parts.
- >> Full guarantee on design and Performance.

PRINCIPLE OF OPERATION

The position-control unit (D/A VP) incorporated in the power cylinder receives a control signal (0.2 to 1.0 kgf/cm²) from a controller and regulates the high pressure air supply to the cylinder to give a corresponding displacement of the position.

The position-control unit operates on the force-balance principle and comprises a diaphragm to receive the control signal, a control spring, one end of which is moved by the piston rod through a cam and bell crank, and a pilot valve to admit and exhaust the high-pressure air supply to the cylinder. When the control signal changes, the diaphragm expands or contracts opening the pilot valve and admitting air to the cylinder to move the piston, any force on the piston less than the designed maximum thrust of the power cylinder will not prevent movement as the pilot valve remains open until the restraining force is overcome and the position requirements are met. The change in the piston's position causes the control-spring force to increase or decrease until a state of equilibrium is reached between the opposing forces of the diaphragm and control spring, the pilot valve is then closed and the piston comes to rest in its new position.

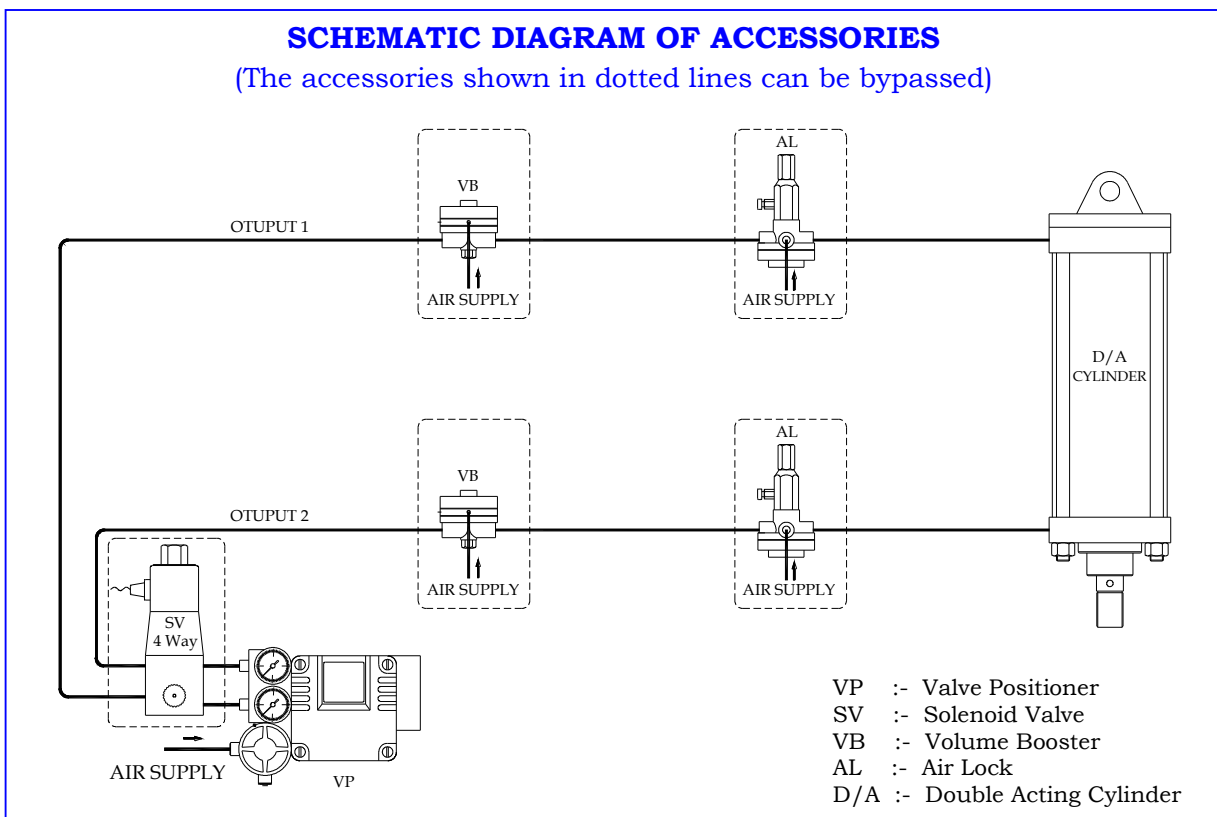

MOUNTING DIMENSIONS OF POWER CYLINDERS

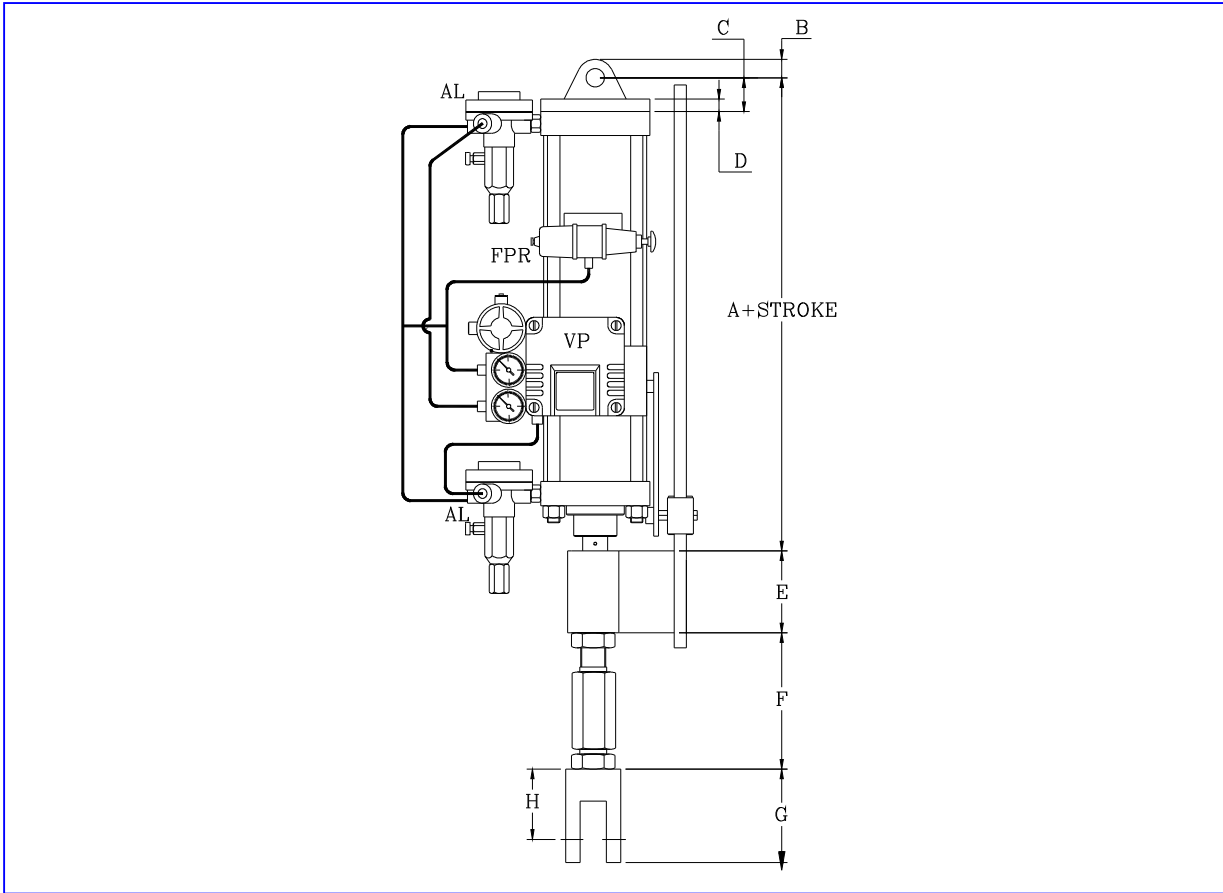

BORE SIZE		A	B	C	D	E	F	G	H	Ø J	K	L
Inch	mm											
2"	50	169	16	16	11	85	130	65	42	12	32	60
2.1/2"	65	190	18	23	12	85	130	65	42	16	40	70
3"	80	210	18	24	14	85	130	65	42	16	50	110
4"	100	186	19	35	15	85	130	65	42	19	76	114
5"	125	217	25	45	20	85	130	65	42	25	89	140
6"	150	225.5	25	49	20	90	130	75	45	25	108	172
8"	200	246	30	58	29	100	130	130	50	41	146	223
10"	250	312	38	64	32	100	130	130	50	44	165	270
12"	300	385	38	96	39	100	130	130	50	41	220	325
14"	350	385	38	96	39	100	130	130	50	41	270	375

The Company's policy is one of continuous product improvement and the right is reserved to modify the specifications contained herein without notice.

ACAD/PVCT / PVCT - PCYL



Plot No: A-35, Road No. 10, Wagle Industrial Estate,
 Thane – 400 604, India.
 Phone: +9122 49620350 / 60, Fax : +9122 2583 8373
 E-Mail: sales@pneuconvalves.com
 Web: www.pneuconvalves.com

BUILT IN RELIABILITY

PVCT – PCYL Designed By : Rajesh

