

INSTALLATION AND MAINTENANCE AND OPERATING MANUAL 'V' NOTCH BALL VALVE SERIES - 370

CONTENTS

Section	Description	Page No.
1	General	1
2	Warnings / Handling	2
3	Pre-Installation / Installation	3
4	Maintenance	4-5
5	Troubleshooting	6
6	Schematic Line Diagram of Accessories	7
7	Valve Assembly Drawings with Part List	8
8	Actuator Assembly Drawings with Part List	8-9

>> 1. GENERAL

This manual describes the instructions for handling, storage, installation, maintenance, and operation of the 'V' Notch Ball Valve and spring opposed pneumatic diaphragm actuator & Rotary actuator.

Instructions not detailed in this document shall be performed in accordance with standard and safe acceptable practices as may be required by local codes, specifications and or regulations.

The instruction contained within this manual must be read before undertaking any work on the equipment supplied and if there are any questions please contact Pneucon Valves Pvt. Ltd. or its agent.

When ordering any spares please specify the unique valve serial number detailed on the equipment nameplate.

If the valve is provided with ancillary equipment e.g. Valve Positioner - Pneumatic , Electro Pneumatic, Smart Positioner, Airset, Solenoid Valve, Air Lock, Volume Booster, I/P Converter, Position Transmitter, Limit – Proximity Switches etc. A copy of the respective ancillary equipment manual will be provided within the data / documentation package supplied with the valve.

>> **2. WARNINGS**

1. In order to avoid possible injury to personnel or damage to any equipment any 'WARNING and CAUTION' notes must be strictly adhered to. Modification of this product, substitution of non-approved components and use of maintenance procedures other than those detailed within this document could drastically affect the performance, nullify any warranty and be hazardous to personnel and equipment.
2. Personal injury, equipment damage, leakage due to escaping gas or failure of pressure containing component may result if the valve or ancillaries are over pressured or installed where service condition exceed the limits detailed in the manufacturer's specification or on the valve nameplate. To avoid such injury or damage a relief valve for over pressure protection should be provide as required by industry and sound engineering practices or applicable safety codes.
3. Due to the possibility of both elevated and low temperatures occurring on exposed surfaces of the valve assembly during operation, adequate safety precautions must be taken. This may involve insulating the valve assembly or the provision of safety clothing and equipment to avoid personal injury.
4. When purchased each valve / ball configuration and construction materials are specifically selected to satisfy the particular application, conditions of flow, temperature, pressure drop and controlled fluid conditions for corrosion and erosion. Included within the Pneucon Valve selection process is the consideration of the amount of power conversion allowed to reduce vibration levels within the valve and also the materials of construction are specifically selected for each application. The valve must not be used on any other application, without a review by Pneucon Valves.
5. The valve is not suitable for fire safe service and is not certified for this application or duty. Unless otherwise detailed in the quotation and order documentation the valve will not have been designed to deal with excessive seismic activity or bending moments resulting from misaligned pipe work.
6. It is not intended that externally applied lever arms will be used on the valve and actuator assembly.

>> **3. HANDLING**

1. The weight of the control valve assembly can cause serious injury if it is not handled correctly, using the necessary protective clothing and safety equipment. Adequate lifting equipment must be used and properly attached. Where lifting eyes are provided with the equipment these should be used to enable safe handling of the valve actuator or assembly. All lifting equipments should be used within its defined limitations., applicable codes and safe industrial practices including (but not limited to) the following :
 - Slings to be free of kinks.
 - Lifting hooks to be positioned directly over the load to avoid any severe swinging when lifted.
 - The operator shall ensure that the load is safe and well secured.
2. When lifting the equipment ensure that any slings or hoists are positioned to avoid any damage to the accessories or tubing mounted on the valve.
3. All eyebolts should have a shoulder, which butts against the tapped hole. Use American Drill Bushing CO ADB2300 series safety hoist rings or equivalent should be used. The following table details the safety hoist thread size and the appropriate safe loading that can be applied.

Safety Hoist Ring	Thread Size UNC	Rated Load lbf
ADB-23004	½" -13 x 0.75	2500
ADB-23002	5/8" -11x1	4000
ADB-23007	¾" -10 x 1	5000
ADB-23101	7/8"- 9 x 1	8000
ADB-23105	1" - 8 x 1.25	10000

>> 4. PRE - INSTALLATION

1. The assembly should be inspected on receipt to ensure that it has not been damaged during transit. This inspection should be undertaken in a safe and controlled manner as valve equipment can be heavy and have sharp edges. Any damage found should be immediately reported.
2. If a valve assembly is required to be stored for a significant period prior to installation it must be stored in a fire resistant, clean, dry and ventilated environment to avoid damage to the valve, actuator or accessories.
3. The end caps or other protection devices should not be removed from the equipment until the time of installation, in order to help avoid any damage to the flanges and also prevent the ingress of dirt or foreign particles.
4. The adjacent pipe work must be free of dirt, pipe scale, welding slag and all other foreign objects. Safe operation of the valve could be impaired by the ingress of line debris or foreign matter. It may be necessary to remove the valve or internals if the pipe work is to be flushed prior to or during the commissioning period.
5. Sufficient clearance above and around the valve and actuator should be provided for access and maintenance purposes.
6. An air supply pressure filter / regulator should be fitted upstream of any instruments mounted on the valve to provide a regulated correct quality air supply pressure as detailed on the valve nameplate.

>> 5. INSTALLATION

1. The valve is supplied with a flow direction arrow either cast on to the body or detailed on the nameplate. It is very important that the valve is installed into the pipe work with the correct flow direction.
2. Install the valve using accepted piping practices and preferably with suitable lengths of straight pipe work both upstream and downstream.
3. The preferred orientation is for the actuator to be vertically upright. If a valve is required to be installed in any other orientation the valve and actuator must be adequately supported.
4. Following installation of the valve an input signal should be applied to the valve actuator in order to check and confirm correct calibration of the assembly.
5. All pneumatic air connections should be checked for leaks. During functional testing of the actuator, the assembly would be subject to a pressure test at 3.4 barg.
6. The gland nuts are factory adjusted and following commissioning further adjustment could be required to stop any stem leakage. It should be pointed out that excessive tightening of the gland studs could result in packing wear or excessive friction.

>> 6. MAINTENANCE

Maintenance such as diaphragm or gland packing or trim replacement can be done without removing the valve from the line.

1. REMOVAL OF ACTUATOR FROM VALVE

- Remove instrument tubing, air set, positiner, and any other accessory that maybe mounted on the control valve unit
- Unscrew the coupling. (Part No:-22)
- Unscrew the actuator from bracket. (Part No:-20)
- Pull off the actuator from the bracket.

2. DIAPHRAGM REPLACEMENT

- Using the spring adjuster the spring compression should be relieved.
- Remove travel indicator and indicator screw. (Part No:-16 & 42)
- Unscrew allenkey bolt of rotary box cover. (Part No:-33)
- Pull off pinion assembly (Pinion + Pinion shaft)
- Unscrew the assembly bolts of rack guide.
- Remove rack from the actuator shaft by rotating the rack anti clock wise.
- Remove the diaphragm case nuts and bolts equally in an alternating pattern. Ensure that all “short” bolting is removed first to separate the casings.
- Remove the diaphragm, diaphragm collar, stem and stem lock nut assembly form the actuator.
- Unscrew the stem lock nut and remove the diaphragm.
- Clean all the internal parts and examine for any damage. Any significantly damaged parts should be replaced.
- Fit the new diaphragm on to the diaphragm collar, stem and stem lock nut assembly and secure the stem lock nut.
- Fit the diaphragm, diaphragm collar, stem and stem lock nut assembly into the actuator.
- Bolt together the diaphragm casings ensuring the bolting is tightened evenly to ensure correct sealing and also prevent damage to casings.
- Using the spring adjuster the spring compression should be applied until the actuator start to operate at the bench set figure detailed on the nameplate.

3. REPLACING GLAND PACKING

- It is recommended that the valve be removed from the line when replacing packing to allow correct set up of the actuator after actuator removal.
- Remove pusher nuts, Pusher and gland.
- Remove the packing parts using a purposed designed packing extracting tool to avoid damaging the packing box bore and shaft surfaces.
- Install the new packing sets fit the gland and pusher. Fit nuts.
- Tighten the packing nuts to compress the packing to seal for operating conditions.

4. ACTUATOR FITTING TO VALVE

- For Valve Action Air to Open Keep the V- Notch Ball Valve in Full closed Position. For valve action air to close keep the V – Notch Ball Valve in full open position.
- Fix the mounting bracket on Valve Body.
- Mount the complete assembly of Diaphragm Operated Rotary Actuator with Rotary Box, to mounting brackets, the back of Rotary box is provided with four tapped holes, whereas mounting bracket has four holes. Align the holes of mounting bracket with tapped holes of Rotary Box and bolt them up. Care should be taken that the two ends of Pinion Shaft and Ball Shaft are in perfect alignment.
- Mount rack on the actuator stem and position it using rack guide.
- Screw the allenkey bolts of rack guide.
- Applying pneumatic signal pressure to the Diaphragm through air connection provided, stroke the valve a few times and set the stroke by using stroke travel stopper provided at the bottom of Rotary Box. If it is a case of regulating duty valve, set the spring compression by using retainer and spring adjuster, through the opening provided on the spring housing.
- Now close the rotary box using cover plate.
- Operate the valve to full stroke and check the V- Notch Ball position.
- If there are any accessories e.g. Limit switches, Solenoid Valve, Air Set, etc. fix them up in their respective places.

5. ACCESSORIES FITTING

- Control valve assemblies generally comprise of a valve, actuator and instrumentation. The instrumentation normally includes a positioner e.g. Pneumatic, E/P or Smart, Volume booster, Airset, Solenoid valve, Air Lock, Quick Exhaust valve and Limit Switches etc.
- The E/P & Smart positioner needs clean, dry and oil-free instrument air to guarantee fault-free operation . Required quality of instrument air according to ISO/DIS 8572-1:
- Solid content and size: class 2
- Pressure dew point: class 2 (not less than 20 K below lowest ambient temperature)
- Contents of oil: class 2
- When working on the compressed air network, ensure that any contamination such as water, oil, swarf, solder residues etc. Is removed by blowing out.
- Each instrument fitted would have a separate operating and instruction manual and this would be included in the data book. This would detail any specific requirements for the instrument.
- Ensure that a suitable air filter is provided for the equipment in accordance with each instrument.
- The pneumatic supply pressure should not exceed the limits detailed for each of the respective instruments.

6. CAUTION

When ordered the valve configuration and construction material were selected to meet particular pressure, temperature, pressure drop and controlled fluid condition. Do not apply other conditions to the valve without getting written consent regarding to suitability from Pneucons authorized representation.

>> 7. TROUBLESHOOTING

Control valve normally require seldom attendance, except for routine check on the control valve response in respect of the input signals received from the controller. The following details some of the problems associated with the control valve operation:

SYMPTOMS	PROBABLE CAUSES	CORRECTIVE ACTION
Excessive leakage when valve closed	Ball in a wrong position relative to the actuator.	Select the correct keyway in the actuator.
	Wrong stop screw adjustment of the actuator.	Adjust the stop screw for closed position.
Valve operation not smooth	Gland flange over tightened	Loosen gland flange nuts and retighten to finger tight
	Inadequate air supply	Check air supply pressure
	Alignment of valve and actuator stem	Check actuator is square and tight on bracket mounting
	Actuator faulty	Service actuator as detailed in maintenance manual
Inadequate flow	Improper Ball adjustment	Refer 'Valve Assembly' section of the manual
	Malfunctioning valve positioner	Bypass positioner and check valve operation with direct signal
Control valve hunting	Input signal fluctuations	Provide steady signal through controller
	Backlash error in moving parts	Remove backlash
	Moisture in air line	Provide dry air supply
	Improper tuning of controller	Adjust the controller settings
Excessive noise	Loose supports	Tighten the supports sufficiently
Valve travel range less than corresponding input signal range	Malfunctioning valve positioner	Bypass positioner and check valve operation with direct signal
	Leakage through diaphragm chamber	Tighten casing bolts and replace diaphragm if necessary
	Excessive tightness of gland packing	Loosen the gland packing slightly
	Line pressure may have increased	Compression spring should be readjusted

SCHEMATIC LINE DIAGRAM OF 'V' NOTCH BALL VALVE ACCESSORIES

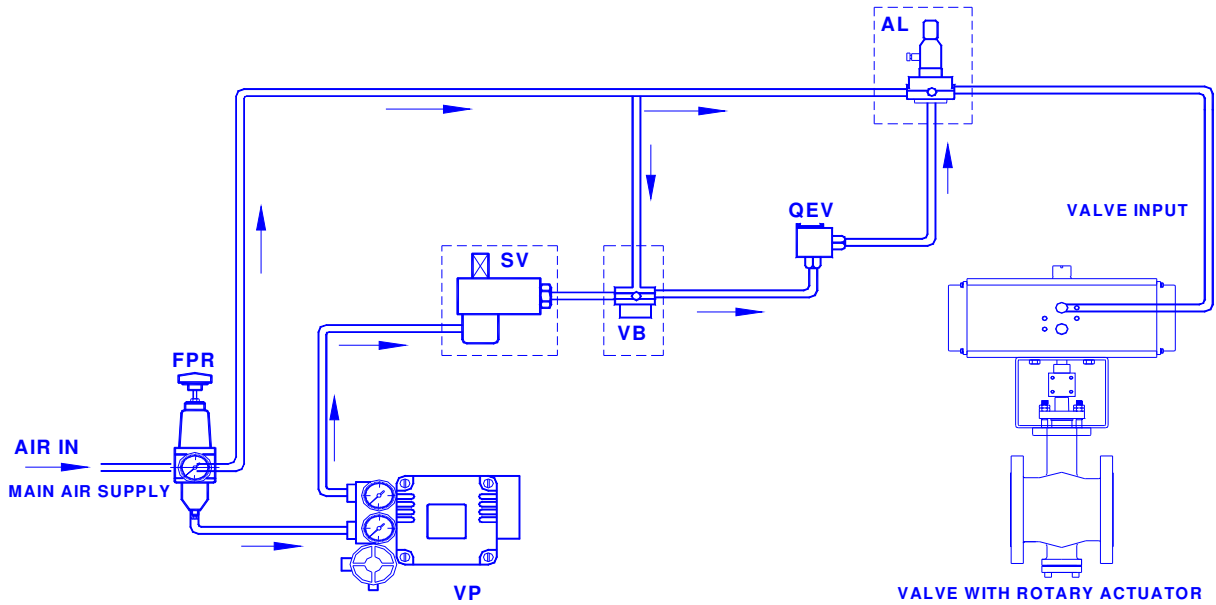
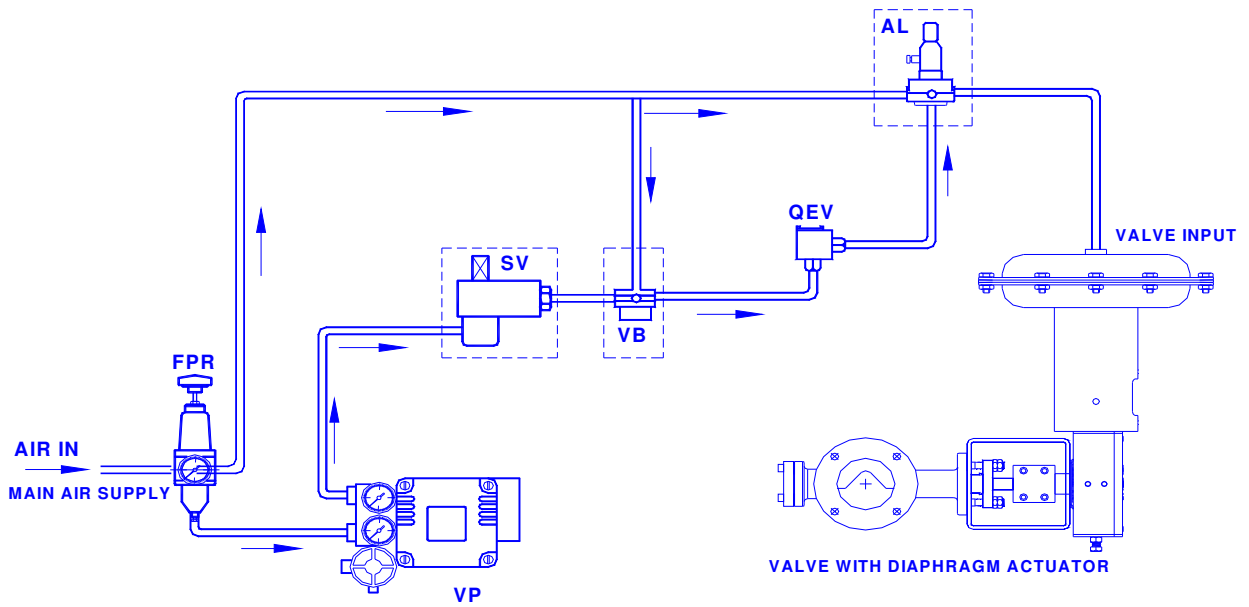

Where,

VP - Valve Positioner-Pneumatic, E/P & Smar
 FPR - Filter Pressure Regulator
 SV - Solenoid Valve

VB - Volume Booster
 QE - Quick Exhaust Valve
 AL - Air Lock

General arrangement of accessories is shown in the schematic diagram. The accessories shown in the dotted line can be bypassed.

'V' NOTCH BALL VALVE (SERIES-370) ASSEMBLY

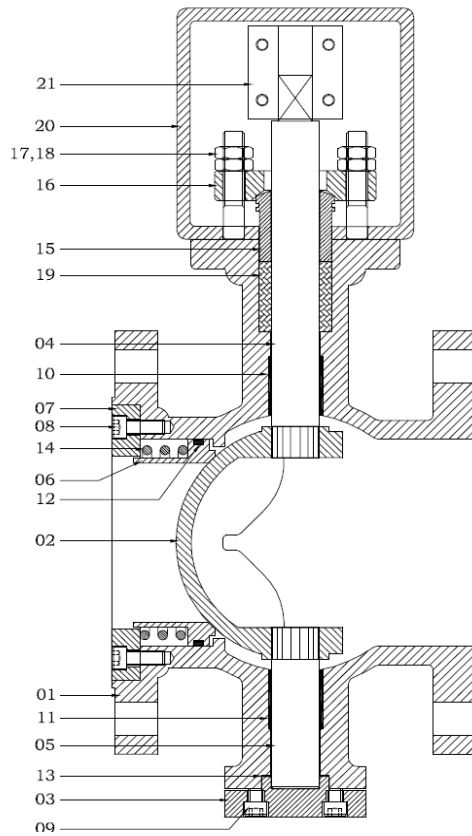

NAME OF PART	PART No.
BODY FLANGED	01
BALL	02
BOTTOM CAP	03
SHAFT-UPPER	04
SHAFT-LOWER	05
METAL SEAT	06
RETAINER	07
ALLEN CAP SCREW FOR RETAINER	08
ALLEN CAP SCREW FOR BOTTOM CAP	09
BALL GUIDE BUSH-UPPER	10
BALL GUIDE BUSH-LOWER	11
'O' RING FOR RETAINER	*
'O' RING FOR BOTTOM CAP	*
SPRING	14
GLAND	15
GLAND PUSHER	16
GLAND STUD	17
GLAND STUD NUT	18
GLAND PACKING	*
BRACKET	20
COUPLING	21

* -RECOMMENDED SPARES

SCOTCH ACTUATOR (MODEL PDR)

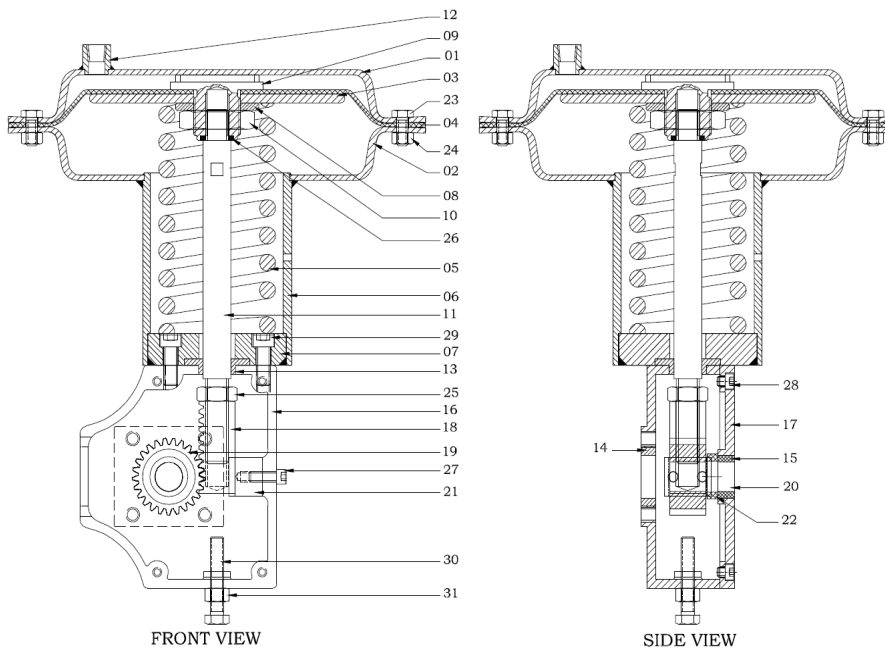

Sr. No.	PART NAME
01	TOP CASING
02	BOTTOM CASING
03	DIAPHRAGM PLATE
04	DIAPHRAGM
05	SPRING
06	SPRING TUBE
07	TUBE END PLATE
08	SPRING GUIDE
09	DIAPHRAGM COLLER
10	DIAPHRAGM COLLER NUT
11	ACTUATOR STEM
12	AIR CONNECTION
13	BUSH FOR STEM
14	BUSH FOR PINION SHAFT GUIDE
15	BUSH FOR ROTARY COVER SIDE
16	ROTARY BOX
17	ROTARY BOX COVER
18	RACK
19	PINION
20	PINION SHAFT
21	RACK GUIDE
22	PINION GUIDE BUSH
HARDWARE	
23	HEX SCREW FOR CASING
24	HEX NUT FOR CASING
25	HEX LOCK NUT FOR RACK
26	SPRING WASHER S.Q. SECTION
27	ALLEN SCREW FOR RACK GUIDE
28	ALLEN SCREW FOR ROTARY COVER
29	ALLEN SCREW FOR MOUNTING ROTARY BOX
30	HEX SCREW
31	HEX NUT

SINGLE ACTING ROTARY ACTUATOR

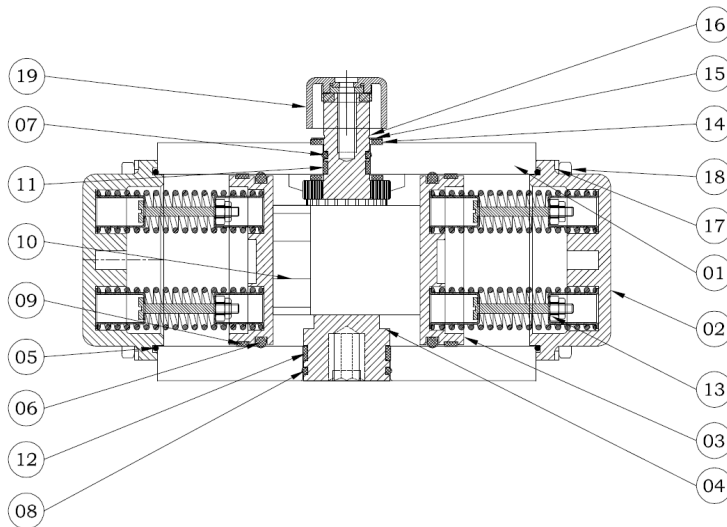

19	INDICATOR	POLYPROPYLENE
18	ALLEN BOLT	SS 304
17	SPRING WASHER	SS 304
16	EXTERNAL CIRCLIP	SPRING STEEL
15	PINION WASHER	SS 304
14	WASHER FOR PINION	DELRIN
13	SPRING CARTRIDGE	-
12	PINION BOTTOM GUIDE	DELRIN
11	PINION TOP GUIDE	DELRIN
10	PISTON PAD	DELRIN
9	PISTON GUIDE	DELRIN
8	PINION BOTTOM 'O' RING	NBR
7	PINION TOP 'O' RING	NBR
6	PISTON 'O' RING	NBR
5	END CAP 'O' RING	NBR
4	PINION	ENS
3	RACK PISTON	ALUMINIUM HE30
2	END CAP	ALUMINIUM HE30
1	BODY	60 63 T6
No	PARTS NAME	MATERIAL

DOUBLE ACTING ROTARY ACTUATOR

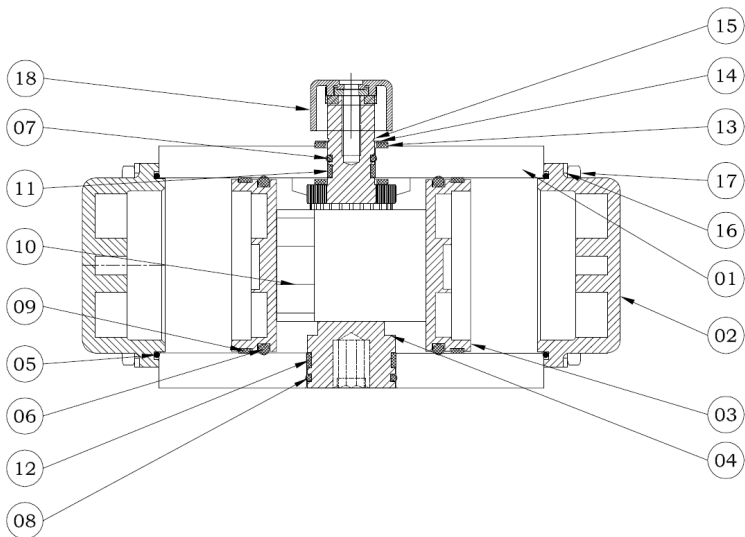

18	INDICATOR	POLYPROPYLENE
17	ALLEN BOLT	SS 304
16	SPRING WASHER	SS 304
15	EXTERNAL CIRCLIP	SPRING STEEL
14	PINION WASHER	SS 304
13	WASHER FOR PINION	DELRIN
12	PINION BOTTOM GUIDE	DELRIN
11	PINION TOP GUIDE	DELRIN
10	PISTON PAD	DELRIN
9	PISTON GUIDE	DELRIN
8	PINION BOTTOM 'O' RING	NBR
7	PINION TOP 'O' RING	NBR
6	PISTON 'O' RING	NBR
5	END CAP 'O' RING	NBR
4	PINION	ENS
3	RACK PISTON	ALUMINIUM HE30
2	END CAP	ALUMINIUM HE30
1	BODY	60 63 T6
No	PARTS NAME	MATERIAL

In order to avoid possible injury to personnel or damage to valve parts, WARNING and CAUTION notes must be strictly adhered to. Modifying this product, substitution non- factory or inferior parts, or using maintenance procedure other than outlined could drastically affect performance, void product warranties and be hazardous to personnel and equipment.

While ordering spares, please indicate 'Valve Serial No.' appearing on 'Name Plate' fixed on the Actuator.

The Company's policy is one of continuous product improvement and the right is reserved to modify the specifications contained herein without notice.



PNEUCON VALVES PVT LTD

Plot No: A-35, Road No. 10, Wagle Industrial Estate,
Thane – 400 604, India.
Phone: +9122 49620350 / 60, Fax : +9122 2583 8373
E-Mail: sales@pneuconvalves.com
Web: www.pneuconvalves.com

BUILT IN RELIABILITY

